



2010
ESCAPE HYBRID
MARINER HYBRID

EMERGENCY RESPONSE GUIDE



FOREWORD

The emergency response procedures for the Escape Hybrid and Mariner Hybrid vehicles are similar to those for traditional gasoline-powered vehicles with the addition of special considerations for the high-voltage electric system components.

The Escape Hybrid or Mariner Hybrid vehicles use a conventional gasoline engine in addition to an electric motor to power the vehicle. The energy used to power the vehicle comes from gasoline (used by the internal combustion engine) and electricity (used by the electric motor).

- Gasoline is stored in a traditional fuel tank.
- Electricity is stored in a high-voltage battery pack.

The combination of a gasoline engine and electric motor provides for improved performance (V6 performance with a 4-cylinder engine and electric motor), reduced emissions and improved fuel economy. The high-voltage system is self contained, never needing to be plugged into an electrical outlet for recharging. The system incorporates a generator that recharges the high-voltage batteries during braking and coasting.

The information in this guide will allow response to emergencies involving Escape Hybrid or Mariner Hybrid vehicles to be as safe as with conventional vehicles.

The Escape Hybrid or Mariner Hybrid vehicles have been designed with many safety features for your protection. These features help provide safe access to the vehicle under various conditions. However, when approaching a high-voltage vehicle in a fire, rescue or recovery situation, always follow one industry standard rule:

***ALWAYS ASSUME THE VEHICLE'S
HIGH-VOLTAGE SYSTEM IS POWERED UP !***

ESCAPE HYBRID AND MARINER HYBRID VEHICLE IDENTIFICATION

- The Escape Hybrid and Mariner Hybrid vehicles can be easily identified by the Ford “green leaf highway” badges located on the left and right front doors. There is a “Hybrid” nameplate on the trunk lid that also includes the “green leaf highway” icon.

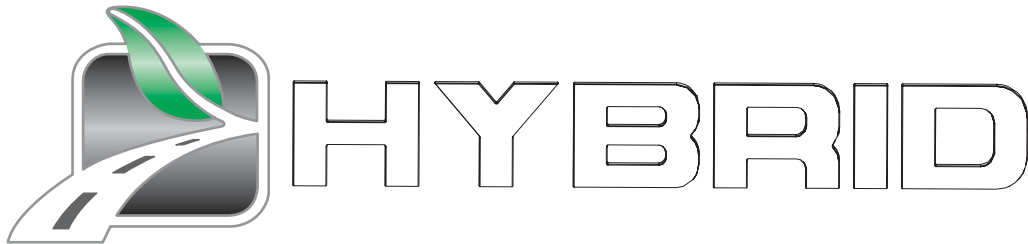

Hybrid Nameplate
with “Green Leaf
Highway” Badge on
Front Door

Hybrid Nameplate
with “Green Leaf
Highway” Badge
on Tailgate

- The Escape Hybrid and Mariner Hybrid vehicles have a unique engine appearance cover with a raised “green leaf highway” icon and HYBRID lettering.

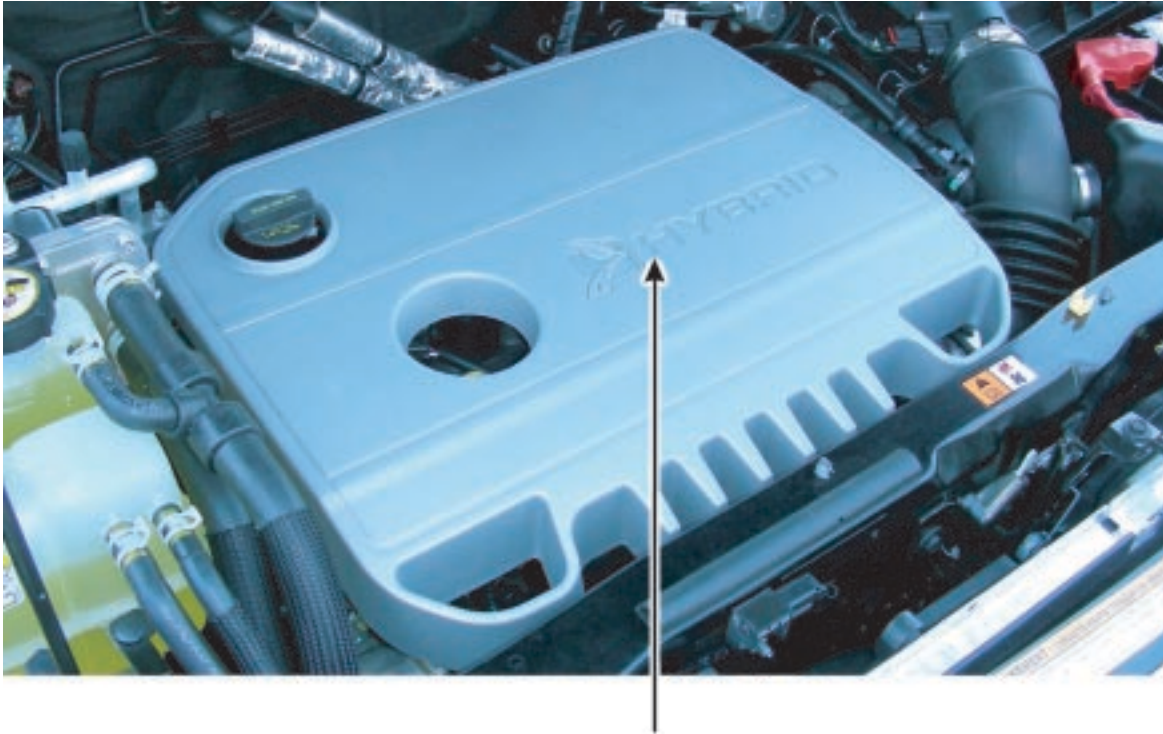

Unique Hybrid Engine Appearance Cover with “Green Leaf Highway” Icon

- The 5th, 6th and 7th digits of the Vehicle Identification Number (VIN) identify the Hybrid vehicle line.

VIN POSITIONS 5, 6 and 7	VEHICLE
N2K	Mariner Hybrid — Front Wheel Drive (FWD)
N3K	Mariner Hybrid — All Wheel Drive (AWD)
U4K	Escape Hybrid — FWD
U5K	Escape Hybrid — AWD

SAMPLE VIN

1 F M C **U 5 K** 3 0 A K A 0 0 0 0 1

↑ ↑
Escape Hybrid AWD

HIGH-VOLTAGE ELECTRICAL AND FUEL DISCONNECT FEATURES

The following list describes certain features that have been incorporated into the Hybrid vehicles that allow for either simple or automatic shutoff of the high-voltage electrical and fuel systems.

- **Inertia Switch – Fuel Pump Shut-Off** — The fuel pump shut-off inertia switch is normally closed to allow vehicle operation. In the event of a collision or a substantial physical jolt, the switch is designed to open automatically, shutting off electrical power to the fuel pump and the high-voltage shut-off switch.
- **Inertia Switch – High-Voltage Shut-Off** — The high-voltage shut-off switch is located behind the jack access panel in the cargo area on the passenger side of the vehicle. In the event of a collision or a substantial physical jolt, the switch is designed to open automatically, disabling the high-voltage system.
- **High-Voltage Fuse** — In the event of a high-current short circuit, the high-voltage fuse will open, disabling the high-voltage system.
- **High-Voltage Interlock Circuit** — Whenever a high-voltage connector is disconnected, the high-voltage interlock circuit opens and disables the high-voltage system.
- **Ignition Key in OFF Position** — Any time the ignition lock cylinder is in the OFF position, the high-voltage system is disabled.
- **High-Voltage Service Disconnect Switch** — Whenever the high-voltage service disconnect switch (located on top of the high-voltage battery in the cargo area) is removed, the high-voltage system is disabled. For additional information, refer to Page 10 in this manual.
- **Thermal Sensors** — In the event the ignition key is left in the ON position, while the vehicle is parked and the high-voltage battery temperature exceeds 60°C (140°F), thermal sensors located inside the high-voltage battery will automatically disconnect the high-voltage battery.

HYBRID COMPONENT LOCATION AND IDENTIFICATION

This illustration provides the locations of the Hybrid system components. Refer to the Hybrid Component Location chart on the following page for descriptions and basic functions of the Hybrid system components.

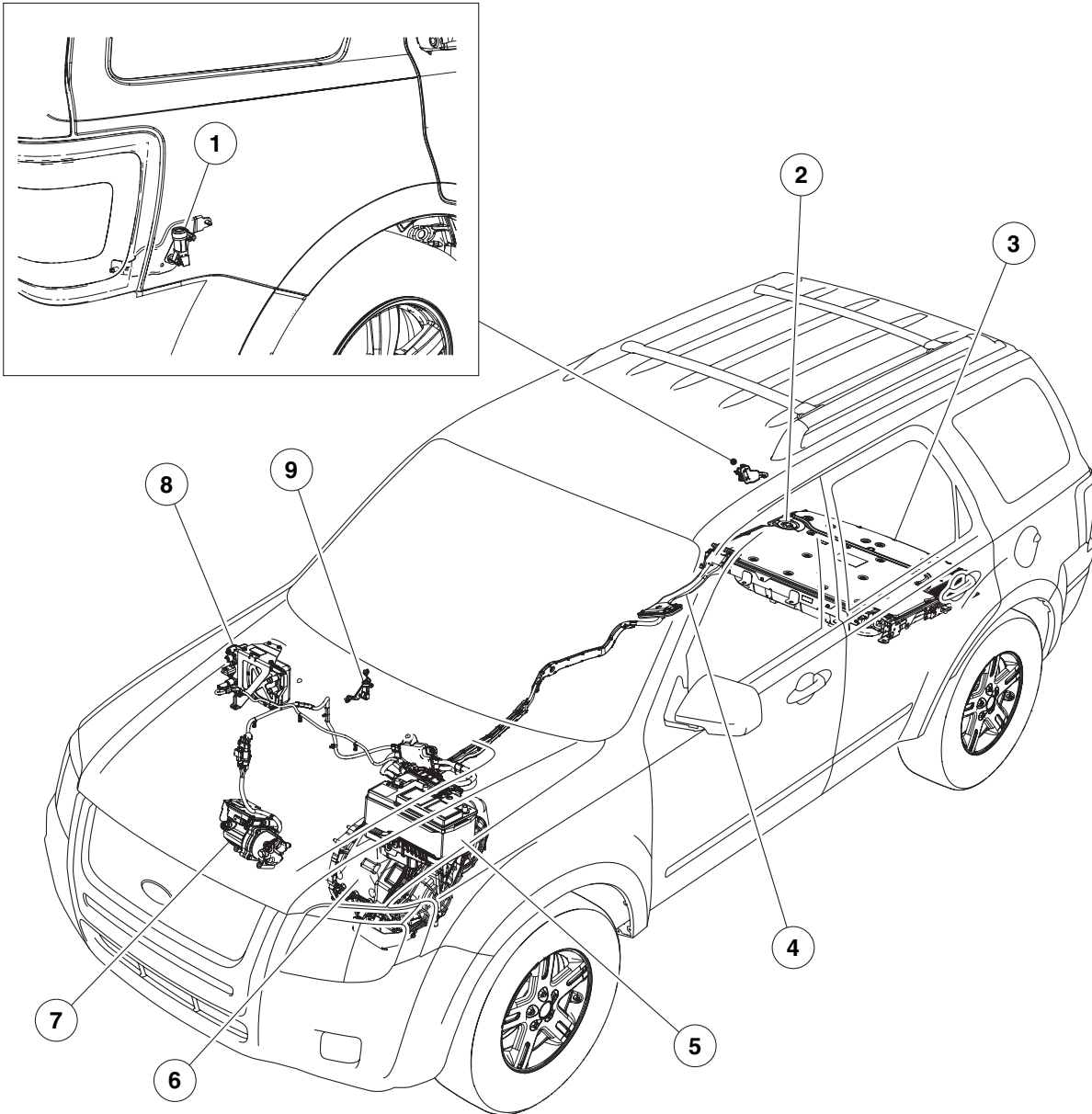

NOTE: All high-voltage wires and harnesses are wrapped in orange-colored insulation.

	COMPONENT	LOCATION/DESCRIPTION	FUNCTION
1	High-Voltage Shut-Off Switch	<ul style="list-style-type: none"> • Located in the jack stowage compartment, passenger side in the cargo area. 	Disconnects high-voltage battery in the event of a collision.
2	High-Voltage Service Disconnect Switch	<ul style="list-style-type: none"> • Located on top of the high-voltage battery, passenger side in the cargo area under carpet. • Orange in color with molded plastic handle, about 100 mm (4 inch) in diameter. 	Provides means to disconnect high-voltage battery for safely servicing vehicle.
3	High-Voltage Battery — 300+ Volts	<ul style="list-style-type: none"> • Located in the cargo area under carpet. • Sealed nickel-metal hydride. 	Provides high-voltage storage (300+ V) for vehicle propulsion requirements.
4	High-Voltage Wiring	<ul style="list-style-type: none"> • Runs along underside of cab floor from high voltage battery to electronically controlled continuously variable transaxle (eCVT) to DC-to DC converter, then the electrical A/C unit. • All high-voltage wiring has orange-colored insulation. 	Provides physical path for high-voltage circuitry.
5	12-Volt Battery	<ul style="list-style-type: none"> • Located under the hood on driver side of the vehicle. • Typical automotive 6-cell lead/acid design. 	Provides 12-volt power for vehicle accessories.
6	Electronically Controlled Continuously Variable Transaxle (eCVT)	<ul style="list-style-type: none"> • Transverse-mounted design similar to the non-Hybrid Escape/Mariner vehicles. • Contains the traction motor, generator motor and Hybrid electronics. 	Provides delivery of power to wheels for vehicle propulsion, generates electricity to recharge the batteries during braking and coasting, and contains certain Hybrid electronics.
7	Electrical A/C Compressor	<ul style="list-style-type: none"> • Located in the front of the engine. 	Provides electrical A/C operation. Replaces the belt driven A/C compressor.
8	DC/DC Converter	<ul style="list-style-type: none"> • Located under the hood on the passenger side forward of the strut tower. 	Provides 12 volts of power to charge the 12-volt battery and run vehicle accessories.
9	Fuel Shut-Off Inertia Switch	<ul style="list-style-type: none"> • Located behind the flip-up panel in the passenger front foot well. 	Disables power supply to the gasoline fuel pump and the high-voltage shut-off switch in the event of a collision.

HIGH-VOLTAGE WARNING DECALS

- Warning decals, as shown here, will be located on components included in the high-voltage system.

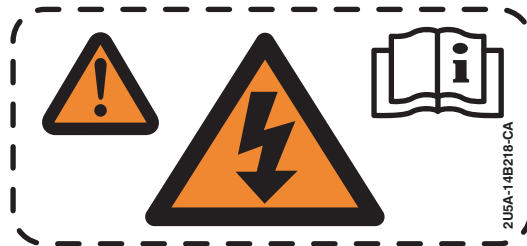

HIGH-VOLTAGE BATTERY PACK

The high-voltage battery pack is located in the rear of the vehicle underneath the carpet.

- The high-voltage battery pack consists of 50 battery modules.
- Each module is comprised of 5 nickel-metal hydride (Ni-MH), 1.3-volt batteries welded together.
- Each battery within the module is similar in size and shape to a size D flashlight battery and is sealed in a stainless steel case.
- The total voltage of the battery pack is approximately 300 volts DC.
- The battery case is designed to be water resistant.
- The battery cells contain a base electrolyte (consisting of potassium hydroxide as the dominant active ingredient) that is absorbed in a special paper. The electrolyte will not leak from the battery under most conditions, however, if the battery is crushed, it is possible for a small amount (drops) of electrolyte to leak.

These warnings must be observed when working with a damaged battery:

1. Exposure to electrolyte could cause skin/eye irritation and/or burns. If exposed, rinse with large amounts of water until the soapy feel is gone. Personal protective equipment (PPE) such as splash shield or safety goggles, gloves (latex, rubber or Nitrile), an apron or overcoat suitable to protect against alkaline and rubber boots are required when handling damaged batteries. Fold-down helmet shields are not acceptable for acid or alkaline spills.
2. If the battery is exposed to intense heat, it is possible that hydrogen could be released from the battery. Appropriate precautions should be taken to make sure the area is properly ventilated, such as, opening the liftgate and vehicle doors and opening or removing the rear glass.

Note: The high-voltage service disconnect switch should be moved to the service/shipping position, if possible.



High-Voltage
Battery Pack

High-Voltage
Service
Disconnect
Switch

High-Voltage
Shut-Off Switch
Located Behind
Jack Access
Panel

HIGH-VOLTAGE SERVICE DISCONNECT SWITCH

WARNING!

- **Removing the high-voltage service disconnect switch disconnects high voltage from the vehicle.**
- **The individual cells inside the battery pack will still be charged.**
- **Do not cut into the high-voltage battery case or penetrate the batteries in any way.**



**High-Voltage Service Disconnect Switch Shown in LOCK position.
High-voltage system is STILL ACTIVE.**

**Remove switch by turning counterclockwise to the unlock position
and place the switch in SERVICE/SHIPPING position
to disconnect high-voltage system.**

APPROACHING A DAMAGED HIGH-VOLTAGE VEHICLE

1. FOLLOW EXISTING TRAINING AND INCIDENT COMMANDER DIRECTION.

- This guide provides only supplemental information as it pertains to the Escape Hybrid and Mariner Hybrid vehicles. The same rules apply when approaching any potential high-voltage situation. Always follow your high-voltage safety training. Some precautions to be taken in any high-voltage situation include:
 - Remove all jewelry (watches, necklaces and earrings). Metal objects are conductors of electricity.
 - Wear the necessary PPEs (high-voltage rubber gloves, face shield, insulated boots, protective raincoat or apron).
 - Bring the following equipment:
 - Class ABC powder-type fire extinguisher
 - A non-conductive object – about 1.5 m (5 ft) long – used to safely push someone away from the vehicle if they accidentally come in contact with high-voltage.

2. APPROACHING A DAMAGED VEHICLE.

- Disable the high-voltage electrical system using as many of the following steps as possible:
 - Secure the vehicle — place the shift lever into the PARK position. Remove the ignition key. Block the wheels, if necessary. Removing the ignition key or turning the key to the OFF position will disconnect the high-voltage system.
 - Disconnect the negative cable from the 12-volt battery – this will also disable the high-voltage system.
 - If possible, remove the high-voltage service disconnect (See Page 10).

SPECIAL NOTES

- If the vehicle is on fire, use a Class ABC powder-type extinguisher to contain and smother the flames. If water is being used, large amounts of water will be required (e.g., from a fire hydrant) to extinguish the flames.
- If the vehicle has any exposed cables, make sure to wear high-voltage rubber gloves and other protective clothing. Do not touch any broken or damaged high-voltage orange cables. Treat severed cables as if they contain high voltage.
- If the vehicle is submerged in water, do not touch any high-voltage components or orange cables while extricating the occupant(s). Do not remove the vehicle until you are sure the high-voltage battery is completely discharged. A submerged high-voltage battery may produce a fizzing or bubbling reaction. The high-voltage battery will be discharged when the fizzing or bubbling has completely stopped.

3. IF THE HIGH-VOLTAGE BATTERY CASE HAS BEEN RUPTURED.

- Just like any other battery, hose the area down with large amounts of water.

4. MOVING DAMAGED VEHICLES — WRECKER DRIVERS.

- Turn the vehicle ignition key to the ACCESSORY position to release the locking steering wheel.
- If possible, remove the high-voltage service disconnect.
- Follow the guidelines in the Wrecker Towing Manual.
 - Front Tow: Wheel Lift (FWD)
 - Rear Tow: Wheel Lift with Dolly (FWD)
 - Flat bed: Front and Rear

5. SPECIAL NOTE TO SALVAGE YARDS.

- If a vehicle with a high-voltage battery is to be scrapped, the high-voltage battery must be disposed of following all local, state/provincial and federal guidelines.