

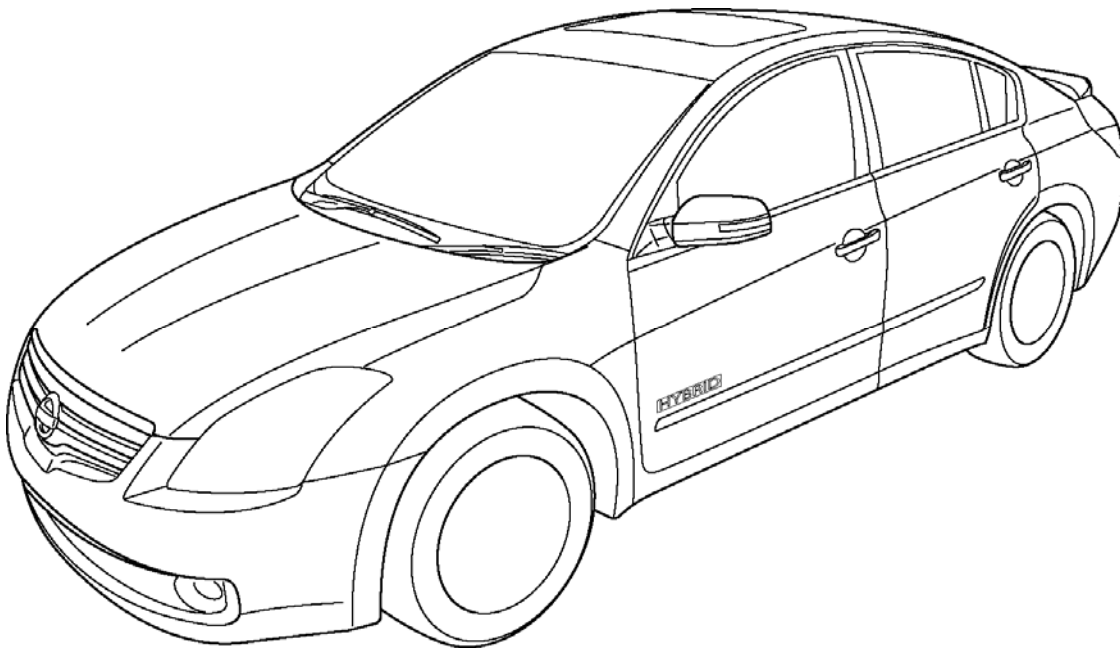

Nissan Altima Hybrid

First Responder's Guide



© 2006 NISSAN NORTH AMERICA, INC.
All rights reserved. This document may not be
altered without the written permission of NISSAN NORTH AMERICA, INC.

Pub. No. FR7E-1H32U0

Foreword	- 3 -
About the Nissan Altima Hybrid	- 4 -
Altima Hybrid Identification	- 5 -
VIN Location.....	- 5 -
Engine Compartment	- 6 -
Hybrid System Locations and Descriptions	- 7 -
12 Volt Battery.....	- 8 -
High Voltage Battery	- 8 -
High Voltage Battery Specifications	- 8 -
High Voltage Battery Recycling.....	- 8 -
Emergency Response	- 12 -
Vehicle Cut Sheet	- 13 -
Extrication	- 14 -
Fire	- 18 -
Recovery/recycling of the Ni-MH high voltage battery	- 19 -
Spills.....	- 19 -
First Aid	- 19 -
Submersion	- 20 -
Roadside Assistance	- 21 -
Towing.....	- 21 -
Fuel-Filler Door Opener	- 21 -
Spare Tire	- 21 -
Jump Starting	- 22 -

Foreword

Nissan released the Nissan Altima Hybrid in North America in January of 2007. The Nissan Altima Hybrid runs on conventional gasoline and a traction motor. The basic vehicle systems and features of the Altima Hybrid are the same as those of the conventional Altima, except where noted in this guide. This First Responder's Guide was published to help educate and assist first responders in the safe handling of the Altima Hybrid and its technology.

A high voltage battery is used to power the traction motor, generator, electric compressor (for air conditioner), voltage converter, and inverter unit. A separate 12 volt battery is used to power other electrical devices such as the radio, horn, headlamps, and instrument cluster gauges. A number of safeguards have been designed to ensure that the high voltage Nickel Metal Hydride (Ni-MH) battery is kept safe and secure in the event of an accident.

The Altima Hybrid utilizes both low and high voltage systems:

Low voltage system

- A 12 volt DC negative chassis ground body electrical system

High voltage system

- A 245 volt DC high voltage battery
- A harness that carries high voltage between the high voltage battery, converter, inverter unit, transaxle and electric compressor
- A converter which converts 245 volts DC to 42 volts DC for the electric power steering
- An inverter unit which delivers up to 650 volts AC to the transaxle
- A transaxle which houses a traction motor and generator
- A 245 volt DC, motor driven electric compressor

High voltage electrical safety is an important factor in the emergency handling of the Altima Hybrid. It is important to recognize and understand the disabling procedures and warnings throughout this guide.

Additional topics in this guide include:

- Nissan Altima Hybrid identification
- Hybrid system component locations and descriptions
- Extrication, fire, recovery, and additional emergency response information
- Roadside assistance information

This First Responders Guide is intended to assist first responders in the safe handling of a Nissan Altima Hybrid. The information contained in this guide is somewhat simplified and intended to be used as a technical reference. Please refer to the Nissan Service Manual for information related to vehicle repair.

About the Nissan Altima Hybrid

There are two power sources stored on board the vehicle:

- Gasoline is stored in a fuel tank and used to supply the gasoline engine.
- Electricity is stored in a high voltage battery and is used to power the traction motor.

The result of combining these two power sources is improved fuel economy and reduced emissions. The gasoline engine also powers an electric generator to recharge the high voltage battery; unlike an entirely electric vehicle, the Altima Hybrid never needs to be recharged from an external electric power source.

Depending on the driving conditions, one or both sources are used to power the vehicle. The following information explains how the Altima Hybrid operates in various driving modes:

1. During light acceleration at low speeds, the vehicle is powered by the traction motor. The gasoline engine is shut off.
2. During normal driving, the vehicle is powered mainly by the gasoline engine. The gasoline engine also powers the generator to recharge the high voltage battery.
3. During full acceleration, such as climbing a hill, both the gasoline engine and the traction motor power the vehicle.
4. During deceleration, such as when braking, the vehicle converts kinetic energy from the front wheels to electricity that will recharge the high voltage battery.
5. While the vehicle is stopped, the gasoline engine and the traction motor are off, however the vehicle remains operational.

Altima Hybrid Identification

In appearance, the Nissan Altima Hybrid is nearly identical to the conventional Nissan Altima.

VIN Location

The VIN can be located on either the front windshield cowl (1) or on the driver's side B-pillar (2).

Example VIN: 1N4CL21E67C051138

An Altima Hybrid is identified by the 4th alphanumeric character: **C**

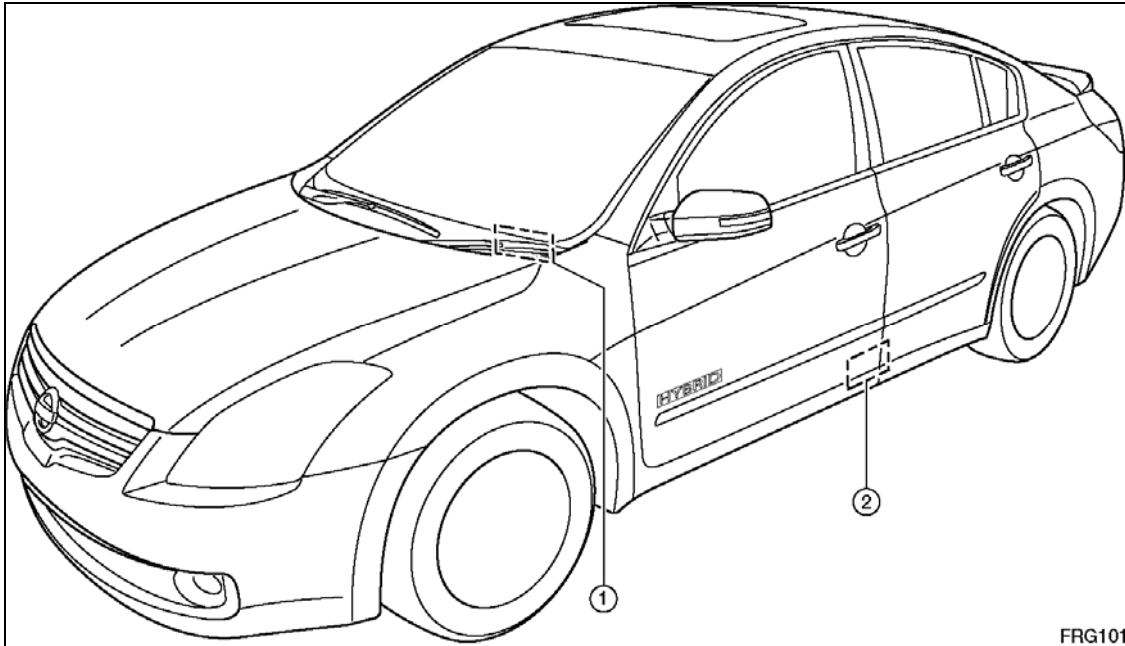

FRG101

Engine Compartment

The engine compartment of the Altima Hybrid houses both an aluminum alloy 2.5 liter gasoline engine and the high voltage inverter unit.

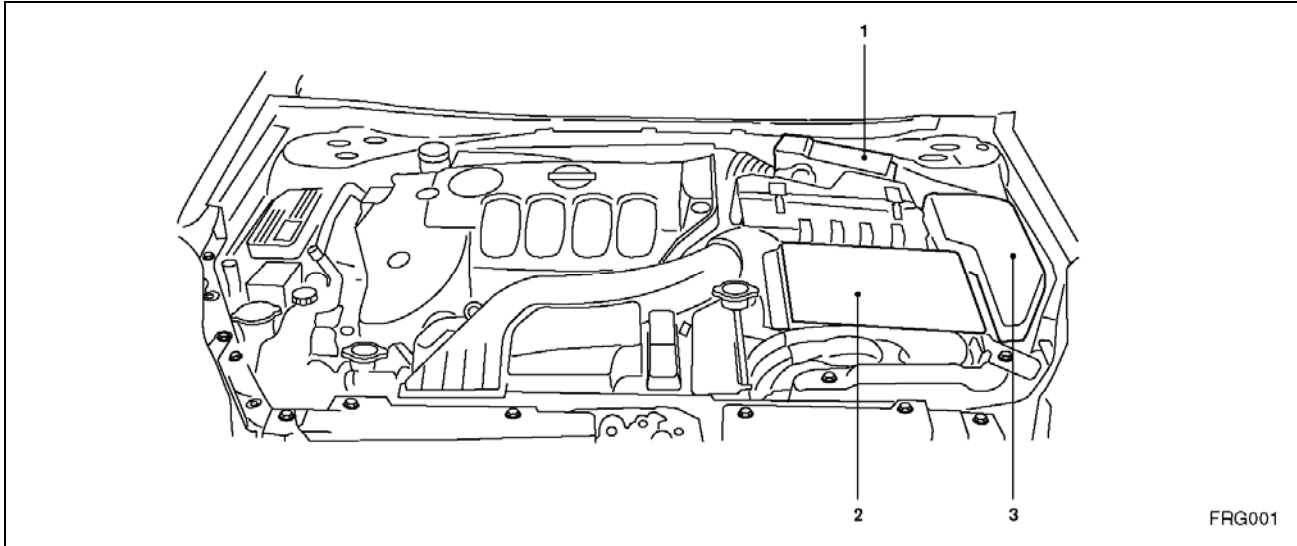

Engine compartment components and locations

Component	Description
1	Fuse/Fusible link box
2	High voltage inverter unit
3	Fuse block

Exterior

- A Hybrid logo is located on the right side of the trunk.

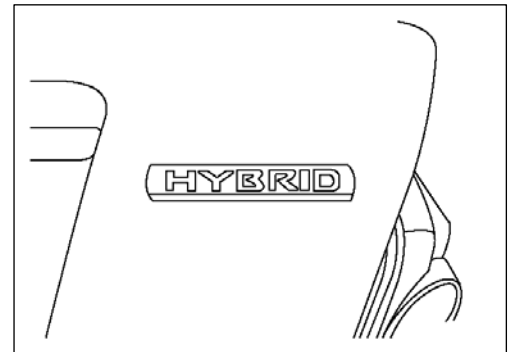

- A Hybrid logo is located on each front door above the body side molding.

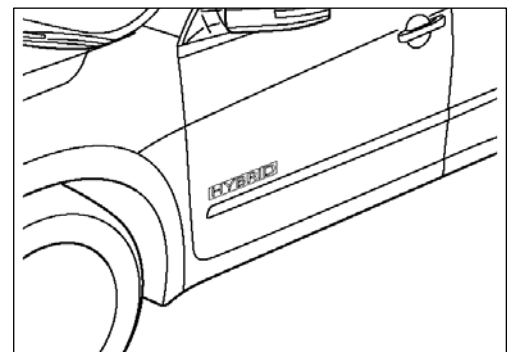

Hybrid System Locations and Descriptions

Component	Location	Description
1. Electric Compressor	Engine compartment	Electric motor driven compressor supplied with 245 volts DC.
2. Electric Power Steering	Engine compartment	A 42 volt DC assist motor is used for the electric power steering (EPS) system.
3. DC/DC Converter	Mounted on top of high voltage battery in trunk area	Converts 245 volts DC to 42 volts DC for the EPS.
4. High Voltage Battery	Trunk area, mounted to cross member and behind rear seat	245 volt DC Nickel Metal Hydride (Ni-MH) battery consisting of 34 low voltage (7.2 volt) modules connected in series.
5. Service Disconnect	Trunk area, located on the right side of the high voltage battery	Used to disable the high voltage system.
6. High Voltage Harnesses	Under passenger side rear seat, floor pan and the left front and back of the engine compartment	Orange colored power cables carry high voltage direct current (DC) between the high voltage battery, inverter unit, and electric compressor. There are two cables which also carry 3-phase alternating current (AC) between the inverter unit and transaxle. NOTE: High voltage cables under the vehicle floor are encased in a black plastic protector.
7. Transaxle	Engine compartment	Contains a traction motor and generator used to power the front wheels and recharge the high voltage battery.
8. Inverter Unit	Engine compartment	Changes the 245 volts DC from the high voltage battery to 3-phase 650 volts AC to power the transaxle. The inverter unit also changes AC electricity from the transaxle to DC that recharges the high voltage battery.

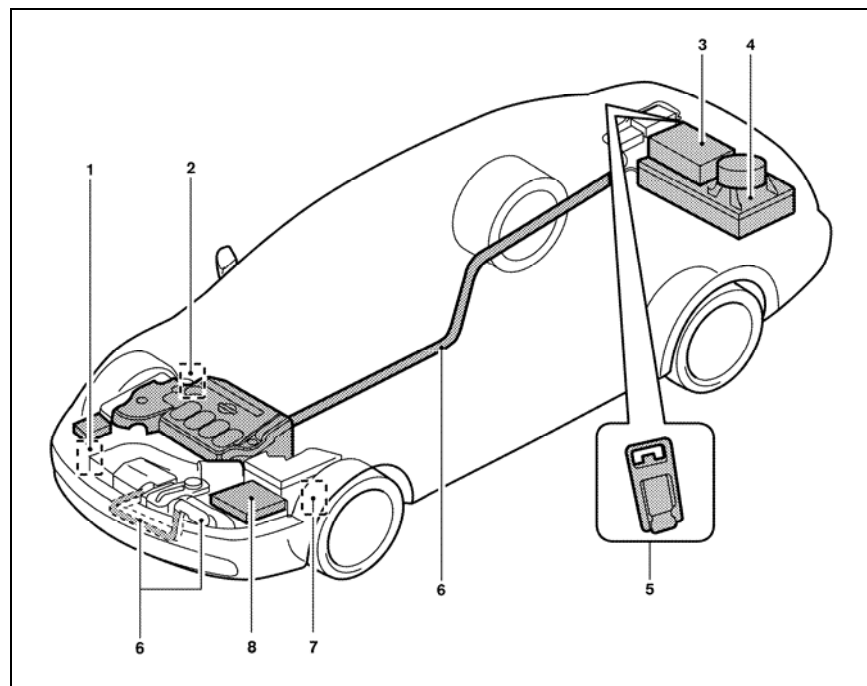

12 Volt Battery

The Altima Hybrid contains a lead-acid 12 volt battery. The 12 volt battery powers the vehicle's low voltage electrical system, similar to a conventional vehicle. As with conventional vehicles, the 12 volt battery is grounded to the metal chassis of the vehicle.

The 12 volt battery is located in the trunk and is concealed by a fabric cover on the passenger side in the rear quarter panel well.

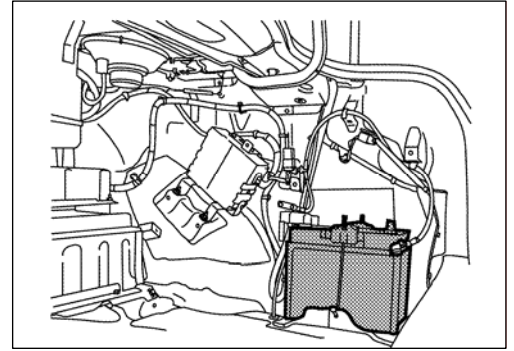

High Voltage Battery

The high voltage battery is enclosed in a metal case and is securely mounted in the trunk area behind the rear seat. The metal case is isolated from high voltage and is concealed by fabric covers. The high voltage battery consists of 34 low voltage (7.2 volt) Ni-MH battery modules connected in series to produce approximately 245 volts DC. Each Ni-MH battery module is sealed in a non-spillable plastic case. The electrolyte used in the Ni-MH battery module is an alkaline mixture of potassium and sodium hydroxide. The electrolyte is absorbed into the battery cell plates and forms a gel that should not normally leak, even in a collision. In the unlikely event that the high voltage battery is overcharged, the modules vent gases directly outside the vehicle through a vent hose.

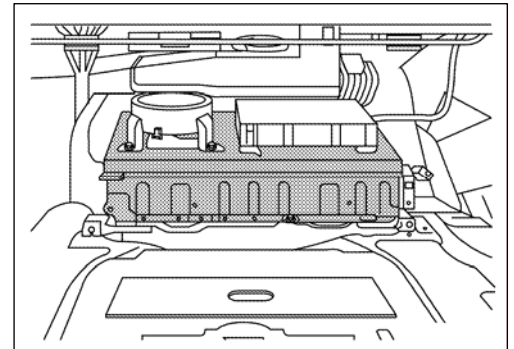

An air vent is located on the rear parcel shelf to cool the high voltage battery. If the vent is covered, the battery will overheat, resulting in reduced output performance of the hybrid system.

The high voltage battery supplies power to the following:

- Power cables
- DC/DC converter
- Inverter unit
- Transaxle
- Electric compressor

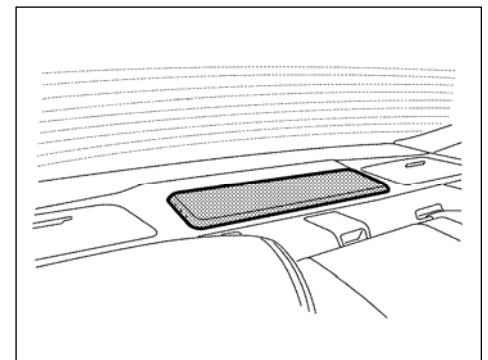

High Voltage Battery Specifications

High Voltage Battery	
High voltage battery voltage	245 V
Number of Ni-MH battery modules in the pack	34
Ni-MH battery module voltage	7.2 V
Ni-MH battery module dimensions	5 x 1 x 11 in. (118 x 20 x 276 mm)
Ni-MH module weight	2.3 lbs (1.0 kg)
Ni-MH high voltage battery dimensions	8 x 34 x 19 in. (190 x 850 x 495 mm)
Ni-MH high voltage battery weight	114.6 lbs (52 kg)

High Voltage Battery Recycling

The high voltage battery is recyclable. Please contact the nearest Nissan dealer or Nissan customer assistance at: United States: 1-800-NISSAN-1 (1-800-647-7261) or in Canada: 1-800-387-0122.

High Voltage Safety System

The high voltage safety system is intended to help keep vehicle occupants and emergency responders safe from high voltage electricity.

High Voltage Safety System

- A high voltage fuse provides short circuit protection inside the high voltage battery.
- Positive and negative high voltage power cables are connected to the high voltage battery and are controlled by normally open system main relays (SMR1 and SMR2). When the vehicle is shut off, the relays stop electrical flow from leaving the high voltage battery.
- The high voltage safety system is insulated from the metal chassis so there is no possibility of electric shock when touching the chassis.

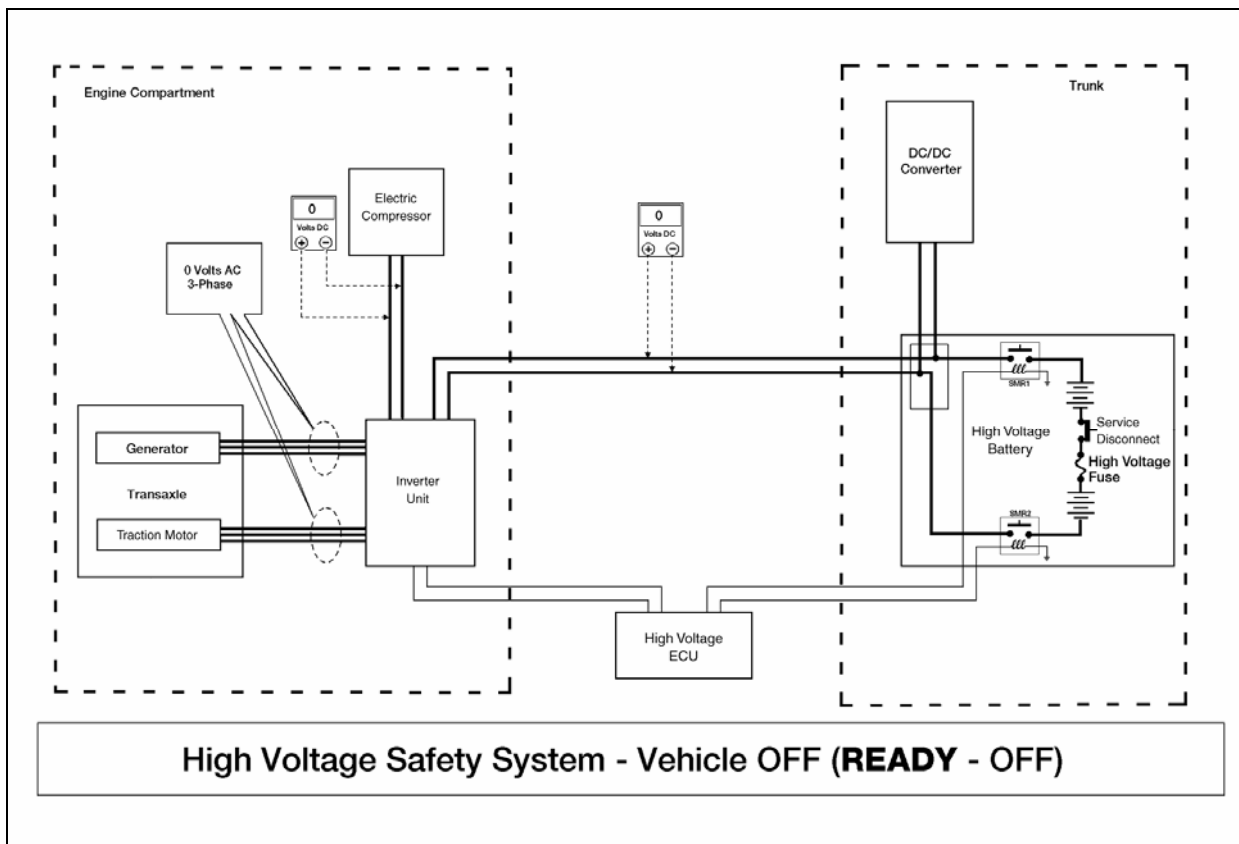

WARNING:

- The high voltage system may remain powered for up to 10 minutes after the vehicle is shut off.
- The high voltage battery retains high voltage at all times.

- A ground fault monitor continuously monitors for high voltage leakage to the metal chassis while the vehicle is running. If a malfunction is detected, the high voltage ECU will illuminate the hybrid system warning light in the instrument cluster.
- The high voltage battery relays (SMR1 and SMR2) will automatically open to stop the electrical flow in a frontal collision that is sufficient enough to activate the supplemental restraint system (SRS).

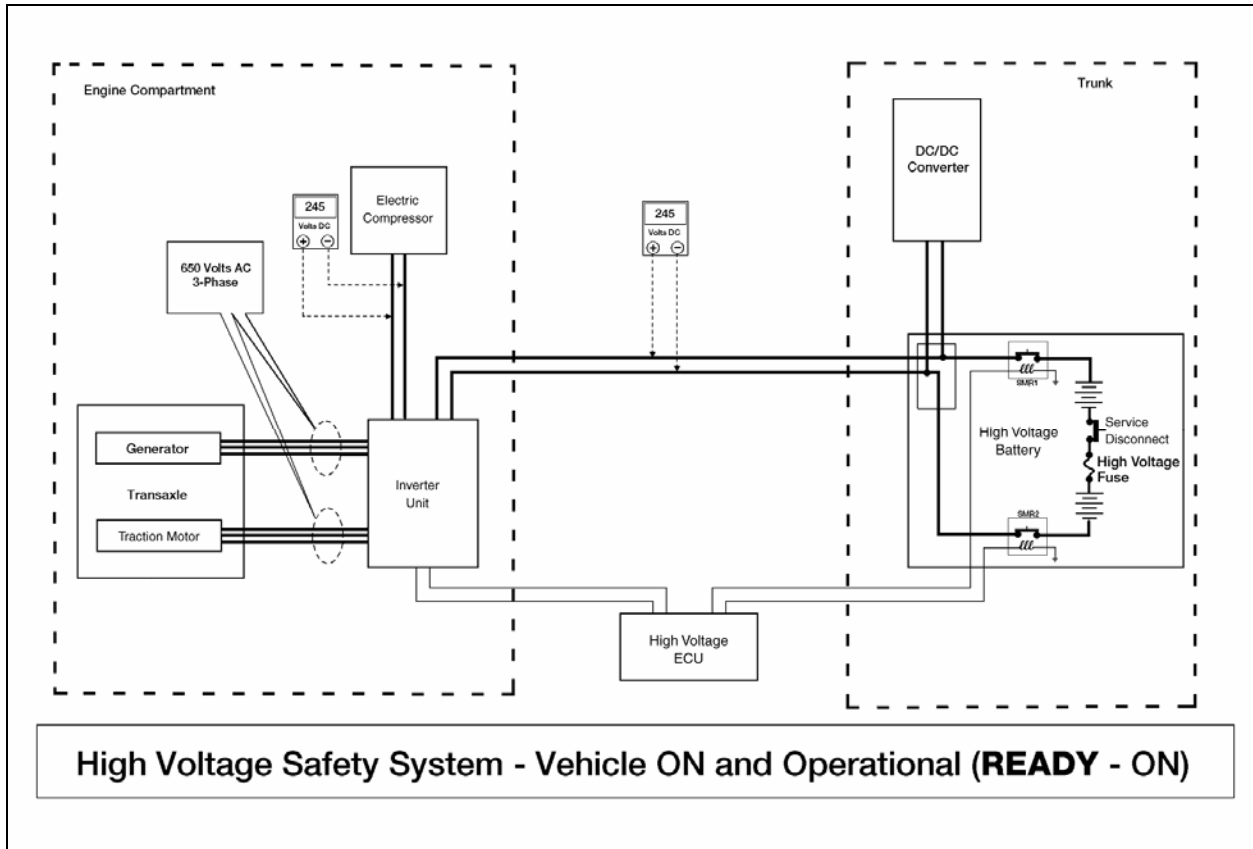

Supplemental Restraint System (SRS) and Seat Belt Pre-tensioners

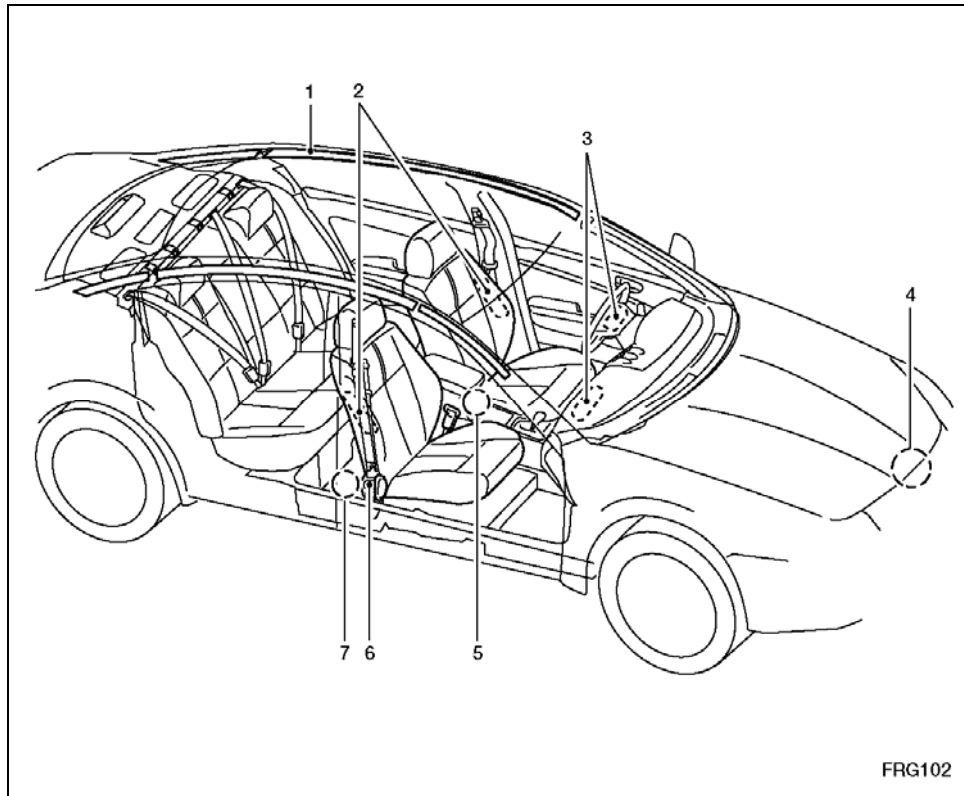

- | | | |
|--|---|---------------------------------------|
| 1. Supplemental curtain side-impact air bags | 2. Supplemental seat-mounted side-impact air bags | 3. Supplemental front-impact air bags |
| 4. Crash zone sensor | 5. Air bag diagnosis sensor unit (control unit) | 6. Seat belt pre-tensioners |
| 7. Satellite sensors | | |

Emergency Response

On arrival, first responders should follow their standard operating procedures for vehicle incidents. Emergencies involving the Altima Hybrid may be handled like other automobiles, except as noted in these guidelines for Extrication, Fire, Recovery, Spills, First Aid, and Submersion.

WARNING:

- Never assume that the Altima Hybrid is shut off simply because it is quiet.
- Always observe the instrument cluster for the **READY** operation indicator light (green) status to verify whether the vehicle is on or shut off. The vehicle is shut off when the **READY** operation indicator light (green) is off.
- The use of personal protective equipment (PPE) such as insulated rubber gloves, insulated rubber boots, and insulated rubber mats must be used when disabling the high voltage electrical system.
- Failure to disable the low and high voltage electrical systems before emergency response procedures are performed may result in serious injury or death from the unintentional deployment of the SRS.
- Failure to disable the high voltage electrical system before emergency response procedures are performed may result in serious injury or death from electrical shock.

Emergency Contact: Nissan @ 1-800-647-7261 (US)
 Or
 1-800-387-0122 (Canada)

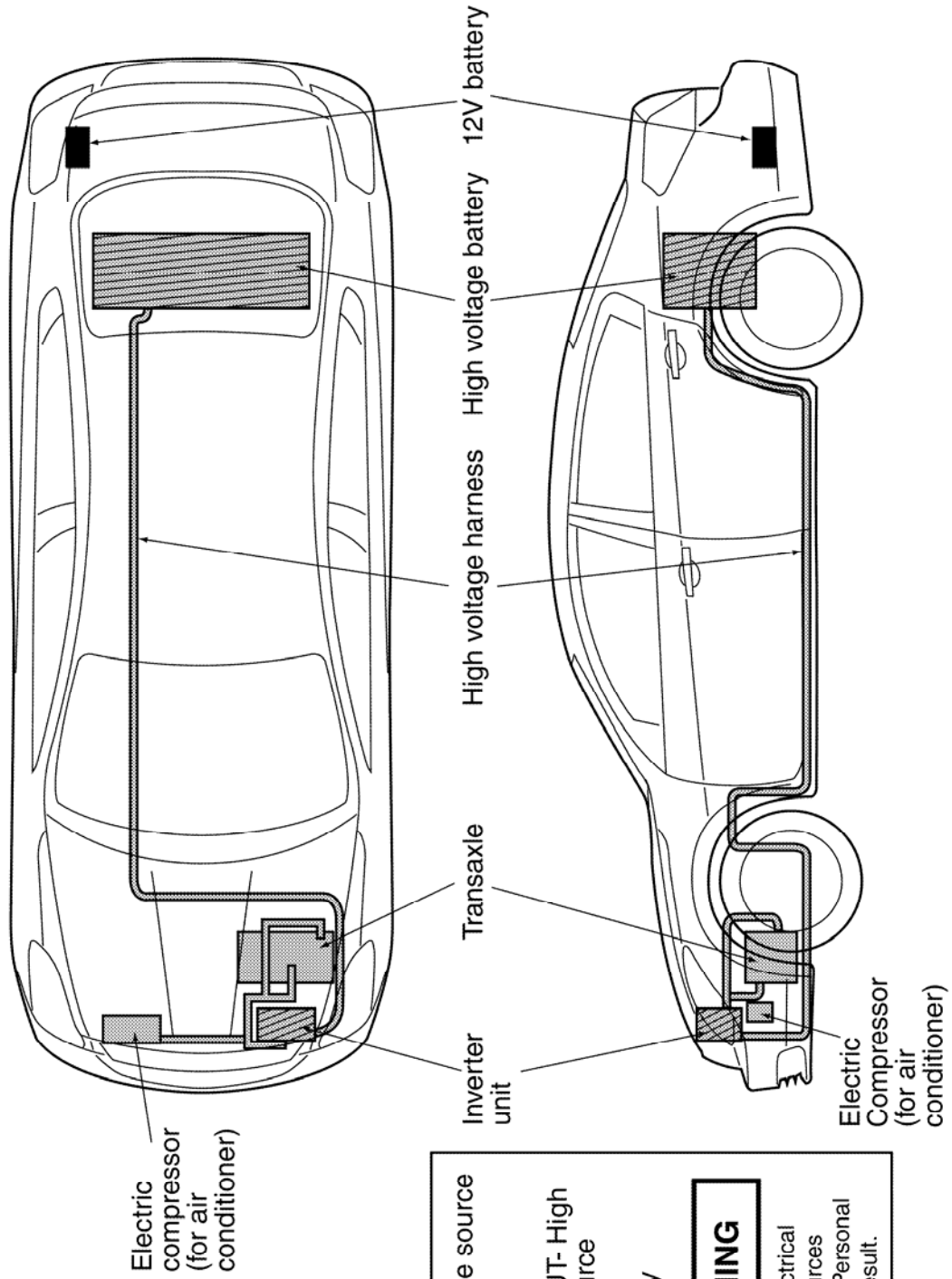

Key

	High voltage source or line
	NEVER CUT- High voltage source
	12V Battery
	WARNING Never cut electrical storages/sources for any reason. Personal injury may result.

December 2006

Nissan North America, Version N (New)

NOTE:

Moving the power seats and operating the power trunk release must be done prior to disconnecting the 12 volt battery.

Extrication

1. Immobilize the vehicle

- a. Move the shift lever to the P (Park) position.
- b. Shut the vehicle OFF by pressing the push-button ignition switch.

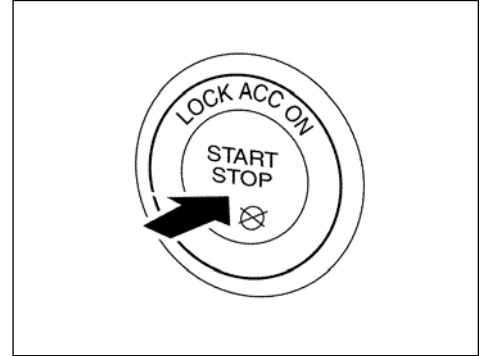

- c. Chock the wheels.
- d. Set the parking brake.

2. Stabilize the vehicle

- a. Crib at four points directly under the front and rear pillars. Do not place cribbing under the high voltage harness, exhaust system or fuel system.

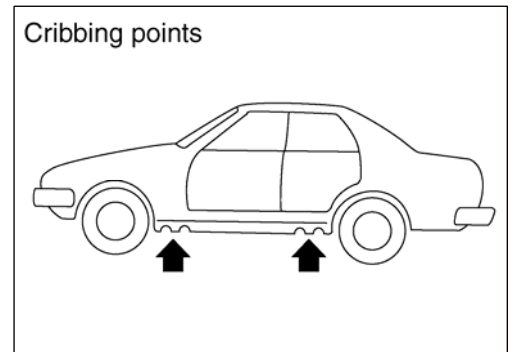

3. Disable the high voltage system

The service disconnect is located behind an access panel inside the lower right-hand side of the trunk. To disable the high voltage system, remove the service disconnect by performing the following:

- a. Pull upward on the service disconnect handle (1).
- b. Rotate the service disconnect handle downward in the direction shown (2).
- c. Pull outward on the service disconnect handle (3).
- d. Disconnect the negative (-) and positive (+) 12 volt battery cables from the 12 volt battery.
- e. Wait 3 minutes before handling SRS system components and 10 minutes before handling high voltage system components while the system discharges.

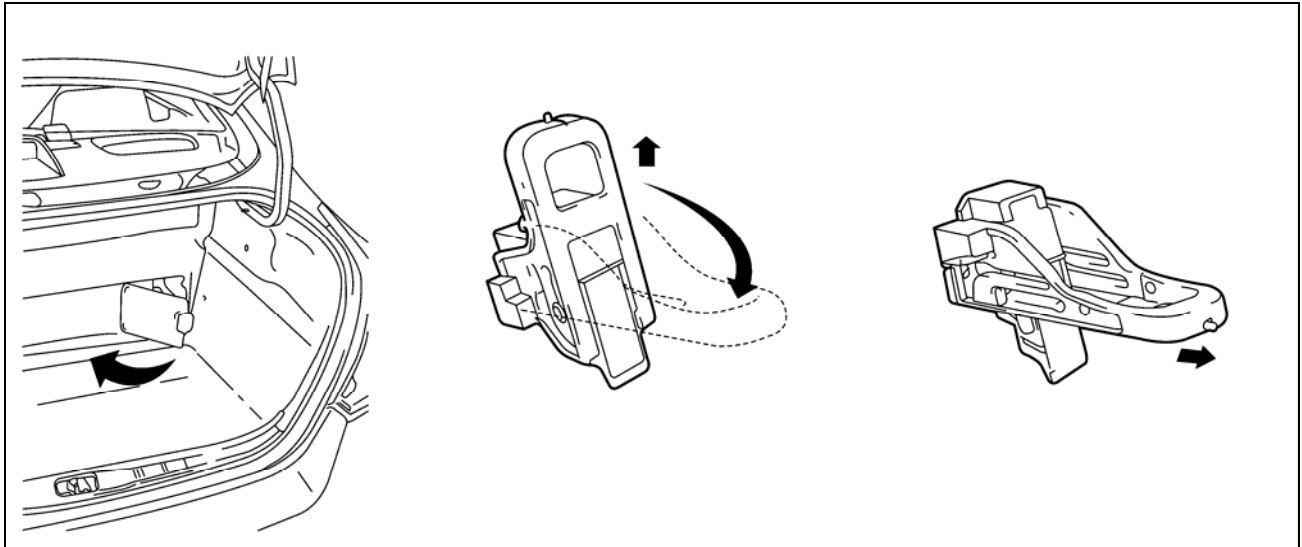

WARNING:

- The high voltage system may remain powered for up to 10 minutes after the vehicle is disabled.
- To prevent serious injury or death from electrical shock avoid touching, cutting, or breaching any orange high voltage power cable or high voltage component while the system discharges.
- The SRS may remain powered for up to 3 minutes after the vehicle is disabled.
- To prevent serious injury or death from unintentional SRS deployment, avoid crushing, cutting, or breaching the SRS components.
- If the disabling procedures cannot be performed completely, proceed with caution as there is no assurance that the high voltage electrical system, SRS, or fuel pump are disabled.

4. Accessing the occupants

- **Glass removal:**
Use normal glass removal procedures as required.
- **SRS awareness:**
First responders need to be cautious when working in proximity of undeployed air bags and seat belt pre-tensioners. Front dual stage air bags automatically ignite both stages within a fraction of a second.
- **Door removal/displacement:**
Doors can be removed by conventional rescue tools such as hand, electric, and hydraulic tools. In certain situations, it may be easier to pry back the vehicle body to expose and unbolt the hinges.
- **Roof removal:**
The Altima Hybrid contains curtain air bags. If undeployed, it is not recommended to remove or to displace the roof. As an alternative, remove the roof panel between the two roof rails.
- **Instrument panel displacement:**
The Altima Hybrid contains curtain air bags. Do not remove or displace the roof during an instrument panel displacement to avoid cutting into undeployed air bags or inflators. As an alternative, instrument panel displacement may be performed using a modified instrument panel roll.
- **Rescue lift bags:**
First responders should not place cribbing or rescue lift bags under the high voltage power cables, exhaust system, or fuel system.

NOTE:

Repositioning the power seats and operating the power trunk release must be done prior to 12 volt battery disconnection.

- **Trunk release:**
The trunk switch is located on the left side of the instrument panel.

To open the trunk, push the switch downward.

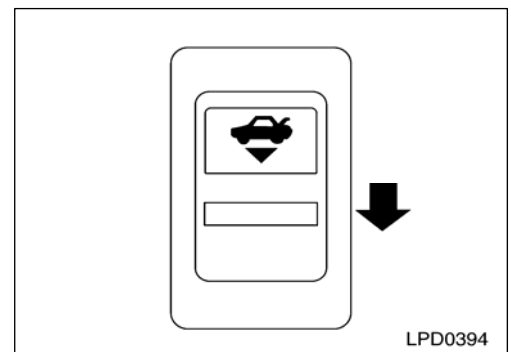

- Secondary trunk release:
Remove the door key from the keyfob as shown.

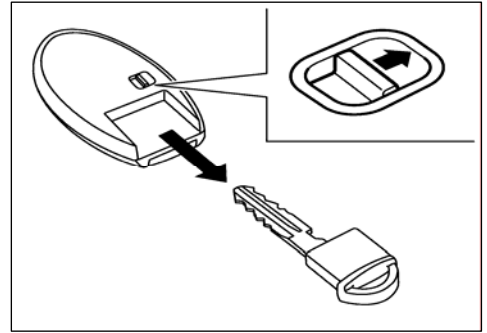

To open the trunk, fold down the rear center seat armrest/cup holder to reveal the trunk compartment access panel. Use the door key to unlock and open the access panel. Pull the trunk release handle (1).

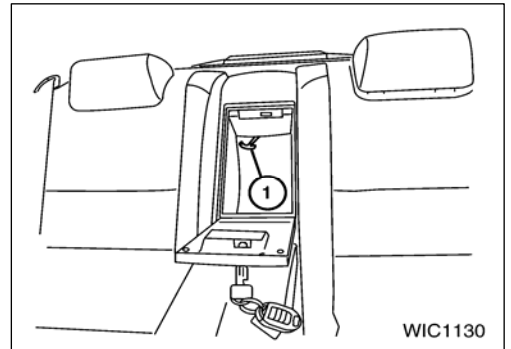

WIC1130

- Repositioning the seats:
The power seat control can be located as shown. Moving the switch forward or backward will slide the seat forward or backward to the desired position. Move the recline switch backward until the desired position is obtained. To bring the seatback forward again, move the switch forward while moving forward.

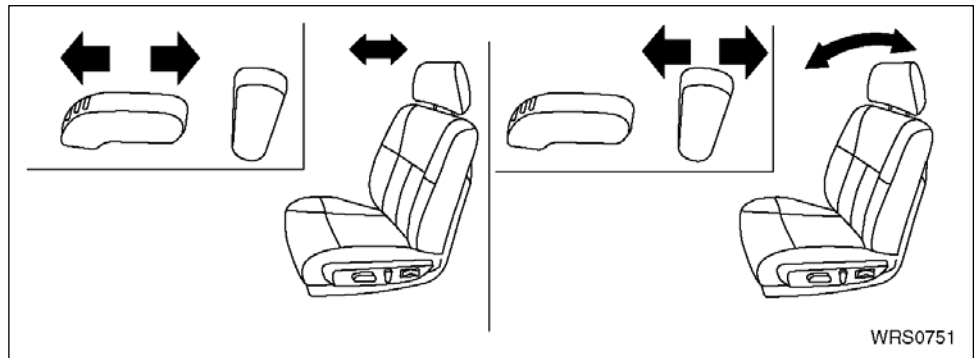

WRS0751

- Repositioning the steering wheel:
The Altima Hybrid is equipped with a tilting telescopic steering column. To adjust the tilt: pull the lever (1) all the way toward you and adjust the steering wheel up or down in the desired direction (2). Release the lever after the desired position has been achieved.

To adjust the telescopic position: pull the lever (1) all the way toward you and adjust the steering wheel forward or backward (3) into the desired position. Release the lever after the desired position has been achieved.

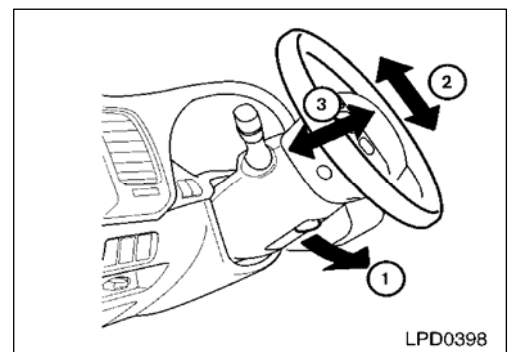

LPD0398

Fire

Approach and extinguish a fire using proper vehicle fire fighting practices as recommended by NFPA, IFSTA, or the National Fire Academy (USA).

- Extinguishing agent
Water has been proven to be a suitable extinguishing agent.
- Initial fire attack
Perform a fast, aggressive fire attack.
Divert the runoff from entering watershed areas.
Attack teams may not be able to identify an Altima Hybrid until the fire has been knocked down and overhaul operations have commenced.
- Fire in a high voltage battery
Should a fire occur in the Ni-MH high voltage battery, attack crews should utilize a water stream or fog pattern to extinguish any fire within the trunk EXCEPT for the high voltage battery.

WARNING:

- The Ni-MH battery electrolyte is a caustic alkaline (pH 13.5) that is damaging to human tissues. To avoid injury by coming in contact with the electrolyte, wear proper personal protective equipment.
- **Never** breach or remove the high voltage battery under any circumstances, including fire. Doing so could result in serious injury or death from electrical shock.

When allowed to burn themselves out, the Altima Hybrid Ni-MH battery modules burn rapidly and can quickly be reduced to ashes except for the metal.

Offensive fire attack

Flooding the Altima Hybrid high voltage battery is not recommended due to the battery case design and location preventing the responder from properly, and safely, applying water through the available vent openings. Therefore, it is recommended that the incident commander allow the Altima Hybrid high voltage battery to burn itself out.

Normally, flooding a Ni-MH high voltage battery with copious amounts of water at a safe distance will effectively control the high voltage battery fire by cooling the adjacent Ni-MH battery modules to a point below their ignition temperature. The remaining modules on fire, if not extinguished by the water, will burn themselves out.

Defensive fire attack

If the decision has been made to fight the fire using a defensive attack, the fire attack crew should pull back a safe distance and allow the Ni-MH battery modules to burn themselves out. During this defensive operation, fire crews may utilize a water stream or fog pattern to protect exposures or to control the path of smoke.

Overhaul

During overhaul, immobilize and disable the vehicle if not already done. Refer to the high voltage electrical system disable procedure located in Extrication. The high voltage battery cover should **never** be breached or removed under any circumstances, including fire. Doing so may result in severe electrical burns, shock and/or electrocution.

Recovery/recycling of the Ni-MH high voltage battery

Clean up of the high voltage battery can be accomplished by the vehicle recovery crew without further concern of runoff or spillage. For information regarding recycling of the high voltage battery, contact the nearest Nissan dealer or Nissan customer assistance at: United States: 1-800-NISSAN-1 (1-800-647-7261) or in Canada: 1-800-387-0122.

Spills

The Altima Hybrid contains the same common automotive fluids used in other non-hybrid Nissan vehicles, with the exception of the Ni-MH electrolyte used in the high voltage battery. The Ni-MH battery electrolyte is a caustic alkaline (pH 13.5) that is damaging to human tissues. The electrolyte, however, is absorbed in the cell plates and should not normally spill or leak out even if a battery module is cracked. Both the metal battery case and the plastic battery modules could be breached if a catastrophic crash occurred.

To neutralize a lead-acid battery electrolyte spill, a diluted boric acid solution or vinegar can be used to neutralize a Ni-MH battery electrolyte spill similar to the use of baking soda.

NOTE:

Electrolyte leakage from the high voltage battery is unlikely due to the battery construction and the amount of available electrolyte contained within the Ni-MH modules. Any spillage would not warrant a declaration as a hazardous material incident. First responders should follow the recommendations as outlined in this emergency response guide.

In an emergency, Nissan Material Safety Data Sheets (MSDS) are available by contacting:

United States: CHEMTREC at 1-800-424-9300

Canada: CANUTEC at *666 or 1-613-996-6666 (collect)

- Handle Ni-MH electrolyte spills using the following personal protective equipment:
 - Splash shield or safety goggles (fold down helmet shields are not acceptable for acid or alkaline electrolyte spills)
 - Insulated rubber gloves
 - Acid-resistant apron
 - Insulated rubber boots
 - Insulated rubber mats (for connect/disconnect of high voltage battery)
- Neutralize Ni-MH electrolyte
 - Use a diluted boric acid solution or vinegar.
 - Boric acid solution = 800 grams boric acid to 20 liters water or 5.5 ounces boric acid to 1 gallon of water.

First Aid

Emergency responders may not be familiar with a Ni-MH electrolyte exposure when rendering aid to a patient. Exposure to the electrolyte is unlikely except in a catastrophic crash or through improper handling. Utilize the following guidelines in the event of exposure.

WARNING:

- The Ni-MH battery electrolyte is a caustic alkaline (pH 13.5) that is damaging to human tissues. To avoid injury by coming in contact with the electrolyte, wear proper personal protective equipment.

- Absorption
 - Perform gross decontamination by removing affected clothing and properly disposing of the garments.
 - Rinse the affected area with water for 20 minutes.
 - Transport patients to the nearest emergency medical care facility.

- Inhalation in non-fire situations
 - Toxic gases are given off as by-products of combustion. All responders in the Hot Zone should wear the proper PPE for fire fighting, including SCBA.
 - Move patients from the hazardous environment to a safe area and administer oxygen.
 - Transport patients to the nearest emergency medical care facility.

- Ingestion
 - Do not induce vomiting.
 - Allow patient to drink large quantities of water to dilute the electrolyte (never give water to an unconscious person).
 - If vomiting occurs spontaneously, keep the patient's head lowered and forward to reduce the risk of asphyxiation.
 - Transport patients to the nearest emergency medical care facility.
 - Contact Poison Control Center at 1-800-222-1222

Submersion

When fully or partially submersed, an Altima Hybrid can be safely handled by following these recommendations:

- Remove the vehicle from the water.
- Drain the water from the vehicle, if possible.
- Follow the immobilizing and disabling procedures.

Roadside Assistance

Nissan Altima Hybrid roadside assistance may be handled like conventional Nissan vehicles, except as noted in the following pages.

Towing

The Altima Hybrid is a front wheel drive vehicle and it must be towed with the front wheels off the ground. Failure to do so may cause serious damage to the hybrid system components.

- A flat bed trailer is the preferred method of towing.
- When towing the vehicle, be sure to release the parking brake.
- The vehicle may be shifted out of P (Park) into N (Neutral) by turning the ignition ON, depressing the brake, and then moving the shift lever to N (Neutral).
- If the shift lever cannot be moved out of P (Park), a shift release button is provided near the shift lever.

To use the shift release button, perform the following:

- a. Remove the shift lock cover as shown.
- b. Insert a small screwdriver in the shift lock release slot and push down.
- c. Move the shift lever to the N (Neutral) position while holding down the release button.

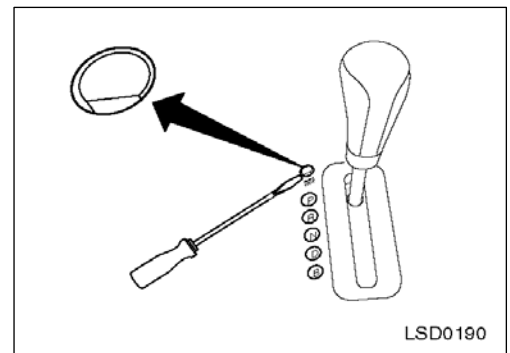

Fuel-Filler Door Opener

The fuel-filler door release is located on the floor to the left of the driver's seat. To open the fuel filler door, pull upward on the release lever. There may be a delay up to 15 seconds before the fuel-filler door opens.

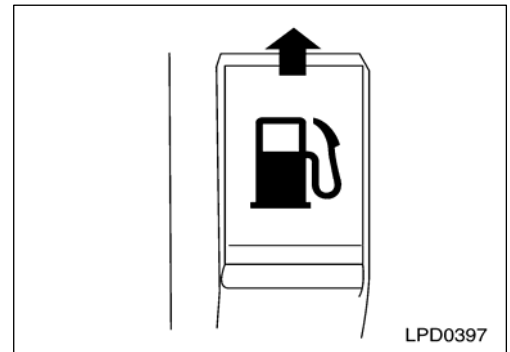

Spare Tire

The jack (1), tools (2), and spare tire are provided in the trunk.

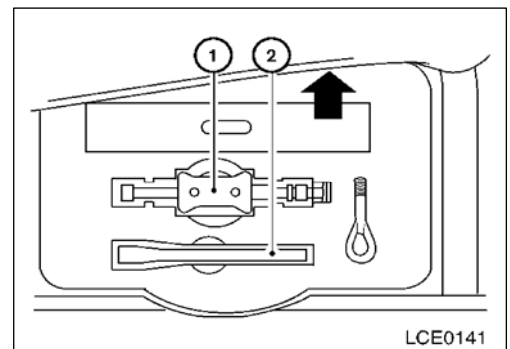

Jump Starting

WARNING:

- The engine may start at any time without warning when the ignition is on and the Hybrid System is in the **READY** mode. When jump starting keep your hands, clothing, hair and tools away from fans, belts and any other parts that can move to avoid personal injury.
- If done incorrectly, jump starting can lead to a battery explosion, resulting in severe injury or death. It could also damage the vehicle.
- Explosive hydrogen gas is always present in the vicinity of the battery. Keep all sparks and flames away from the battery.
- Do not allow battery fluid to come into contact with eyes, skin, clothing or painted surfaces. Battery fluid is a corrosive sulfuric acid solution which can cause severe burns. If the fluid should come into contact with anything, immediately flush the contacted area with water.
- Whenever working on or near a battery, always wear suitable eye protectors (for example, goggles or industrial safety spectacles) and remove rings, metal bands, or any other jewelry. Do not lean over the battery when jump starting.
- Do not attempt to jump start a frozen battery. It could explode and cause serious injury.
- The vehicle has an automatic engine cooling fan. It could come on at any time. Keep hands and other objects away from it.
- Always follow the instructions below. Failure to do so could result in damage to the charging system and cause personal injury.

1. Locate the HEV fusible link box located behind the engine air cleaner.
2. Push the tab (A) in and lift up to remove the lid and expose the remote positive (+) battery terminal (B).

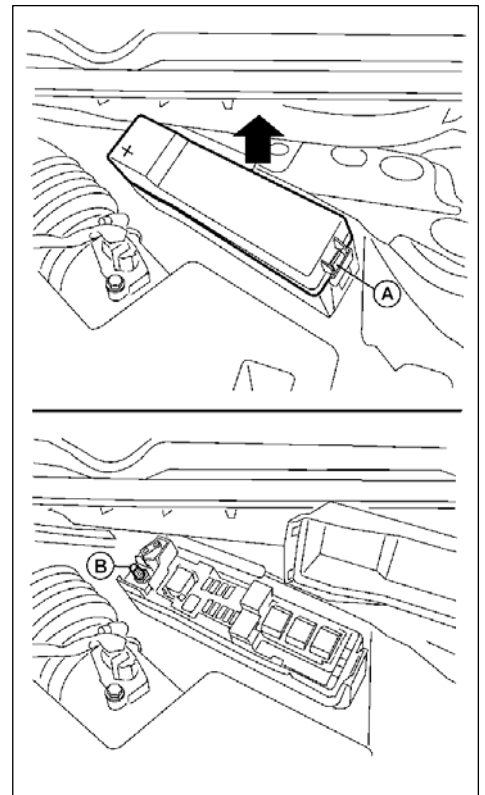

3. If the booster battery is in another vehicle, position the vehicles (E) and (F) shown in the illustration below, to bring the batteries near each other.

Do not allow the two vehicles to touch.

4. Apply the parking brake. Move the shift lever to P (Park). Switch off all unnecessary electrical systems (lights, heater, air conditioner, etc.).
5. Remove the vent caps (if so equipped) on the booster battery and cover the battery with an old cloth (G) to reduce the explosion hazard.
6. Connect jumper cables in the sequence illustrated (A), (B), (C), (D).

CAUTION:

- The booster battery must be rated at 12 volts. Use of an improperly rated battery can damage the vehicle.
- Always connect positive (+) from booster vehicle to remote positive (+) battery terminal.
- Always connect negative (-) from booster vehicle to body ground (for example, strut mounting bolt, engine lift bracket, etc.).
- Make sure the jumper cables do not touch moving parts in the engine compartment and that the cable clamps do not contact any other metal.

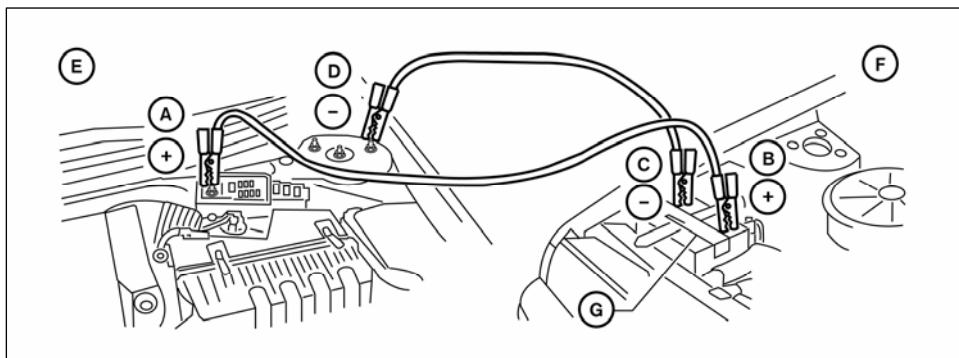

7. Start the engine of the booster vehicle and let it run for a few minutes.

8. Hold down the brake pedal and press the START button. The vehicle instrument cluster will light up, and the **READY** operation indicator light (green) will come ON.
9. After the **READY** operation indicator light (green) in the instrument cluster comes ON, carefully disconnect the negative cable and then the positive (+) cable.

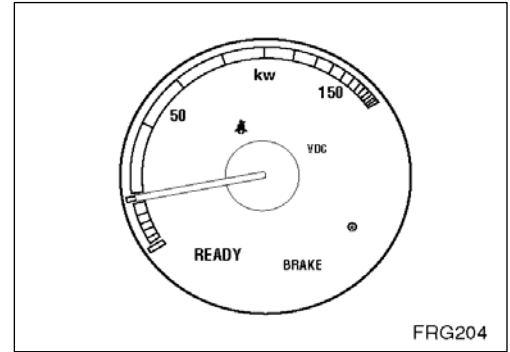

CAUTION:

- If the **READY** operation indicator light (green) does not come on, press the START button to turn the Hybrid System OFF. Carefully disconnect the negative (-) cable, then the positive (+) cable. Have the vehicle taken to a Nissan dealership for repair.

10. Replace the vent caps (if so equipped). Be sure to dispose of the cloth used to cover the vent holes, as it may be contaminated with corrosive acid.

The high voltage battery **CANNOT** be jump started.