



Volvo Cars of North America, LLC.

Organization	Type of document		
Volvo Cars of North America	Safety Information		
Name of document	Issue	Issue date	Page
Volvo Vehicle Extrication	1	July 2004	1 (1)
Issuer (dept, name, CDS id, phone, location)	Reg No.	Retention Period	Security class
Regulations & Compliance, Automotive Safety			Public
Receiver (dept, name, location)			

The following information is a compilation of SRS component descriptions and locations for Volvo vehicles from the MY 1987 240 to the present MY 2005 V50.

Being focused on safety, Volvo has assembled these Guidelines for Emergency Personnel Attending Traffic Accidents.

Volvo strongly recommends that all rescue personnel, in the interest of their own and vehicle occupant safety, become familiar with the type and location of particular SRS components for each Volvo model described herein, and heed all recommendations for safeguarding against accidental or incidental deployment both during and after rescue.

For comments or if additional information is needed about Volvo vehicles and crash safety, please contact:

Bruno DiGennaro,
Sr. Safety Engineer
Volvo Cars of North America, LLC
1 Volvo Drive
Bldg B Regulations & Compliance
Rockleigh, NJ 07647

Phone: 201-784-4574
Fax: 201-784-4989

Re: Information for
emergency personnel
attending traffic accidents.

NO.

11

DATE

July-04

Bulletin for Emergency Personnel attending traffic accidents.

240/700/S40(-04)/V40/
940/960/S90/V90/850/ S70/
V70 (-00)/C70/V70 XC (-00)/
V70 (00-)/V70 XC (01-)/
XC70/S60/S80/XC90/
S40(04-)/V50/V40/
850,S70,V70/S60,V70,
S80

M/Y 1987-

Page 1 of 43

- Remarks:** This quality information includes the S40(04-)/V50/850,S70,V70/V40 S60,V70,S80.
- Distribution:** Involved markets.
- Involved markets:** All markets.
- Background:** This information is intended for emergency personnel about the safety systems in Volvo's in the event of an extrication due to a traffic accident.

Information regarding the Volvo safety restraint system

Since 1987, Volvo cars have been equipped with advanced occupant restraint systems designed to supplement the protection provided by seat belts. These are called Supplemental Restraint System module (SRS).

Different models and model year Volvo's are equipped with various types of active components of the SRS including seat belt pre-tensioners, frontal driver and passenger airbags, SIPS bag (front occupant side airbags), inflatable curtains (IC), and ROPS (Roll Over Protection Systems).

Not all of these components are present in all models.

Additionally, these pre-tensioners, airbags, and curtains have been designed with pyrotechnic or electrostatic deployment systems - each with unique handling requirements - in various locations throughout the car.

Recognizing this complexity and being focused on safety, Volvo has assembled these Guidelines for Emergency Personnel Attending Traffic Accidents.

Volvo strongly recommends that all rescue personnel, in the interest of their own and vehicle occupant safety, become familiar with the type and location of particular SRS components for each Volvo model described herein, and heed all recommendations for safeguarding against accidental or incidental deployment both during and after rescue.

This bulletin contains:**Page Content**

General information	3
Location of SRS components 240	4
Location of SRS components 700	5
Location of SRS components 940/960, S90/V90	6
Location of SRS components 850/S70/V70 (-00), C70 coupé/C70 convertible	9
Location of SRS components S80/V70 (00-)/V70 XC (01-)/XC70	23
Location of SRS components S40/V40	27
Location of SRS components S60	30
Location of SRS components XC90	32
Location of SRS components S40 (04-)/V50	34
Location of decals showing the existing airbag system in the car	37
Interrupt the power supply	42
Information about laminated side window glass	43

General information

Vehicles with SRS Systems:

The first thing emergency personnel should do is to disconnect the electrical power supply by disconnecting the battery. **The back-up power function of the SRS can retain voltage for approximately 10 seconds after the power supply has been disconnected.** Emergency personnel should avoid applying direct force on any of the SRS components.

The battery for S80/V70 (00-)/V70 (01-)/XC70/S60/XC90 are located in the cargo compartment (trunk).

Note! When the battery is disconnected, the following components cannot be operated if they are electronically controlled:

- Power seats
- Power sunroof
- Central locking
- Power window

After an SRS component has deployed, it is then possible to mechanically handle it without concern of further deployment. Precautions should be taken when working in the area of non-deployed components.

Powder is spread out into the vehicle when the airbag is activated. The powder is generated during airbag deployment. The powder may cause skin irritation.

This powder can be washed off with normal tap water. If the powder gets into the eyes, wash with plenty of water.

If an SRS equipped vehicle is on fire: SRS components are designed to deploy under conditions of excessive heat. The system is designed to deploy the SRS components when the temperature on the gas generator reaches 230° C (450° F).

It should be noted that it takes a serious fire to deploy the SRS components, which means that the SRS components will not deploy in all type of fires.

Note! The **SIPS bags** in the front seats have either **mechanical** or **electrical** systems. Electrical SIPS systems can be deactivated by disconnecting the battery. Mechanical SIPS bags **CANNOT** be deactivated so care must be taken not to impact the sensor located in the base of both front seats. See model descriptions for mechanical or electrical system and component location.

- **For vehicles with inflatable curtains**, if the roof needs to be cut open, avoid cutting the gas tubes for the inflatable curtain system which are located in the C/D-pillar area. See model description for component location.
- **C70 Convertibles** are equipped with ROPS located behind the rear seat headrests. The ROPS is deployed by a mechanical spring and contains no pyrotechnics.
- The **WHIPS** is an anti-whiplash mechanical system which requires no special handling.

Explanation of abbreviations used in this document:

SRS	Supplemental Restraint System
SIPS	Side Impact Protection System
ROPS	Roll Over Protection System
IC	Inflatable Curtain (airbag curtain located above side windows).
WHIPS	Whiplash Protection System (located in the base of the two front seats).
ECM	Engine Control Module
OWS	Occupant Weight Sensor (located in the passenger seat)
PLP	Pyrotechnical Lap belt Pre-tensioner

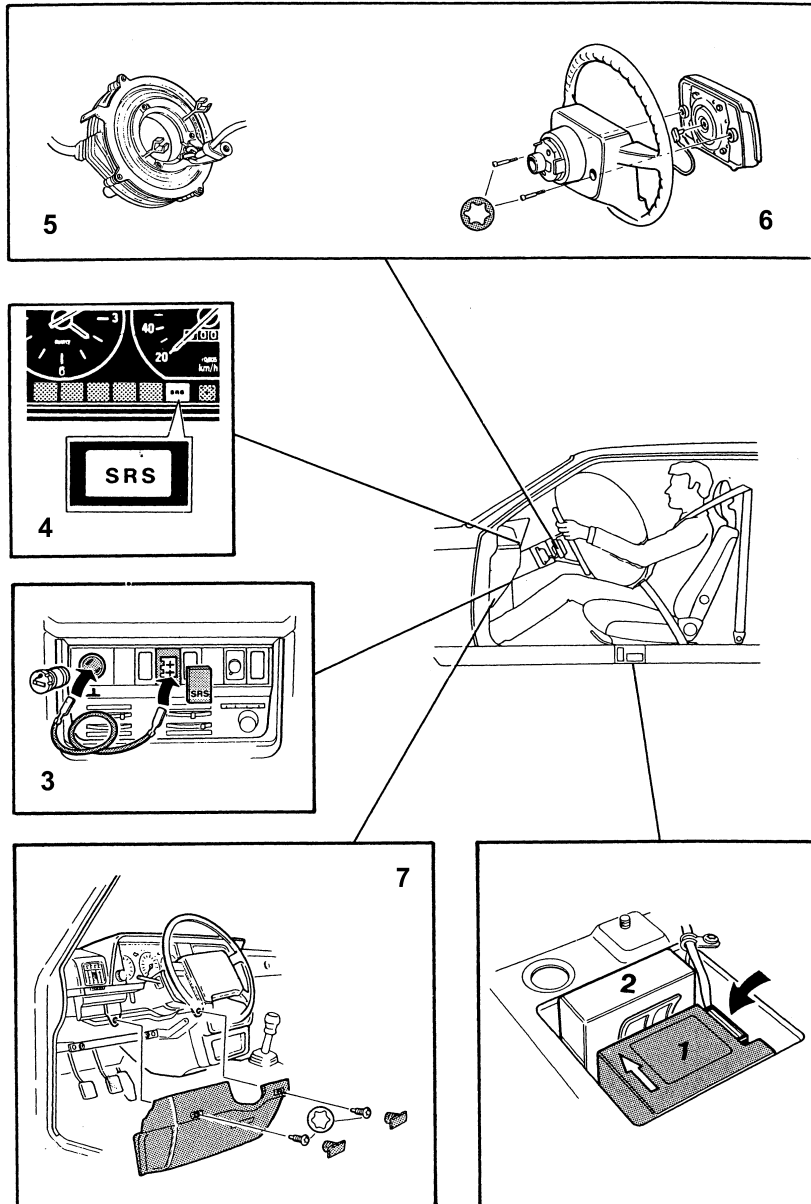

8803081S

SRS components, 240 1987-

- 1: Collision sensor
- 2: Standby power unit
- 3: Test output
- 4: SRS indicator lamp
- 5: Contact Reel
- 6: Steering wheel module
- 7: Knee bolster (USA/Canada)

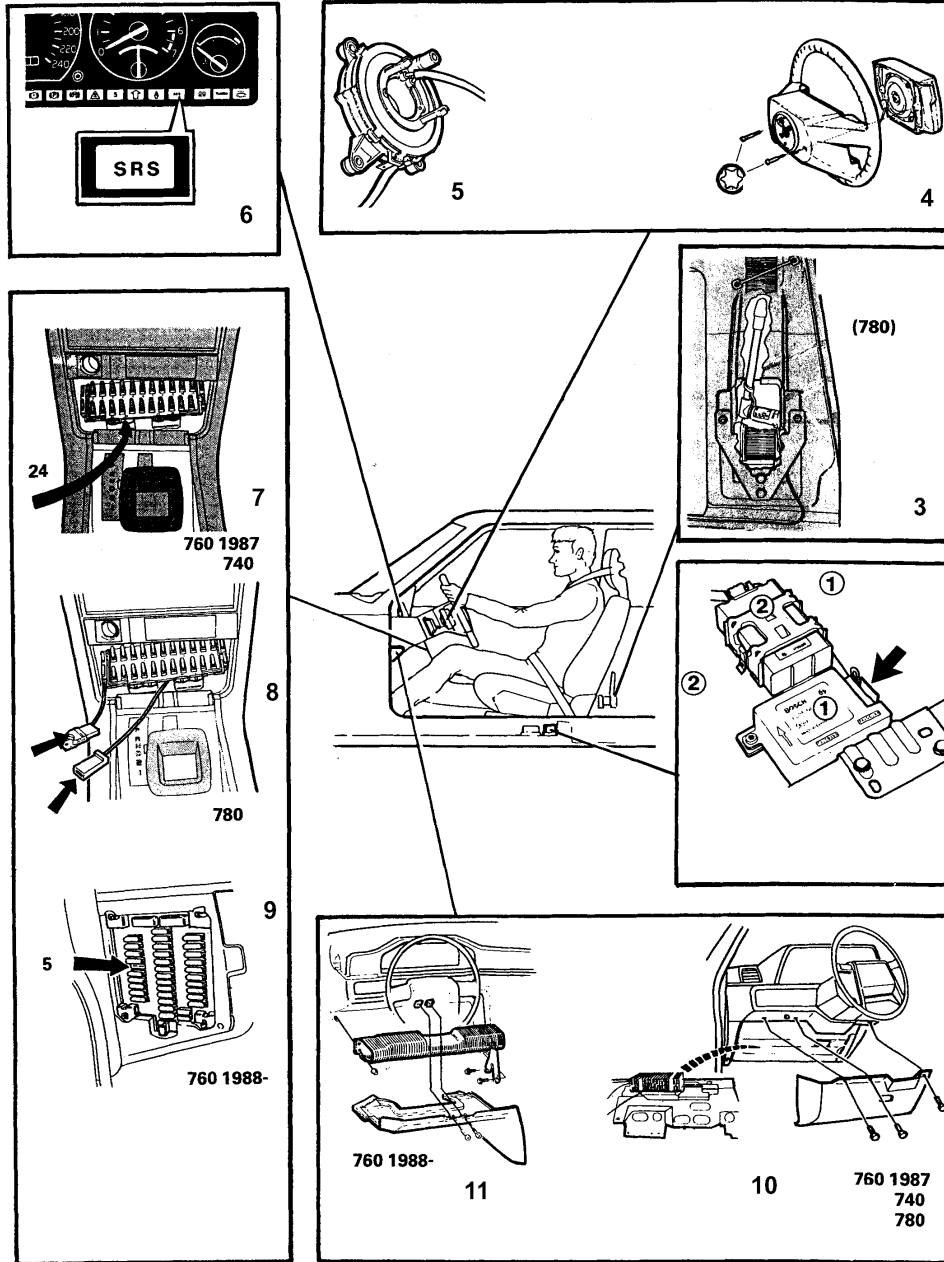

8803082S

SRS components, 700 1987-

- 1: Collision sensor
- 2: Standby power unit
- 3: Seat belt tensioner (pyrotechnic) 780
- 4: Steering wheel module
- 5: Contact reel
- 6: SRS indicator lamp
- 7: Test output 760-1987/All 740
- 8: Test output 780
- 9: Test output 760-1988-
- 10: Knee bolster 760-1987/All 740/All 780
- 11: Knee bolster 760-1988-

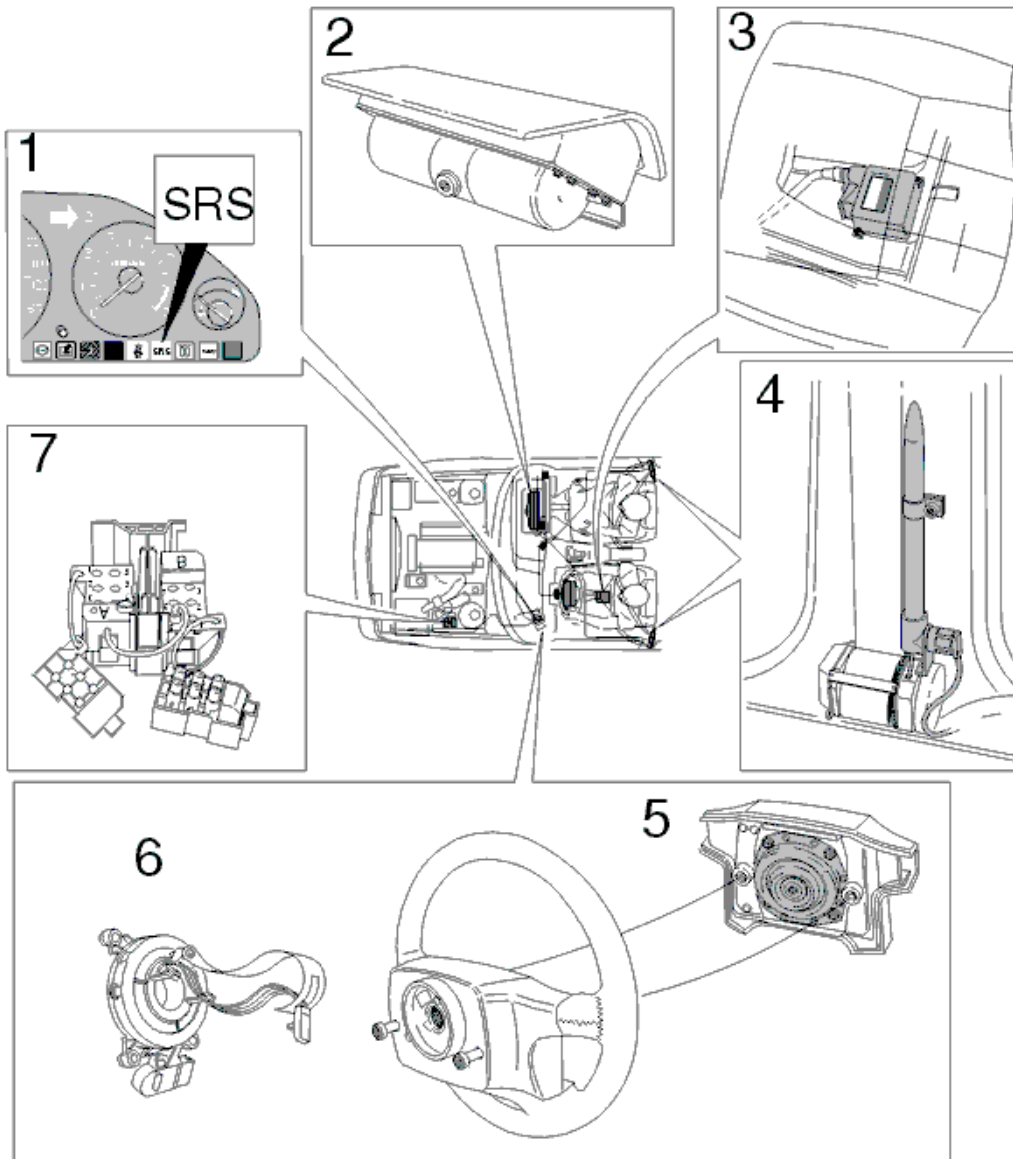

8800218A

SRS components, 940/960 1991-1996

- 1: SRS indicator lamp
- 2: Passenger airbag (from model year 1993)
- 3: SRS sensor module and back-up power unit
- 4: Seat belt pre-tensioner (mechanical up to 1991 inclusive, pyrotechnic from model year 1992).
- 5: Driver airbag
- 6: Contact Reel
- 7: Data link connector (in the engine compartment)

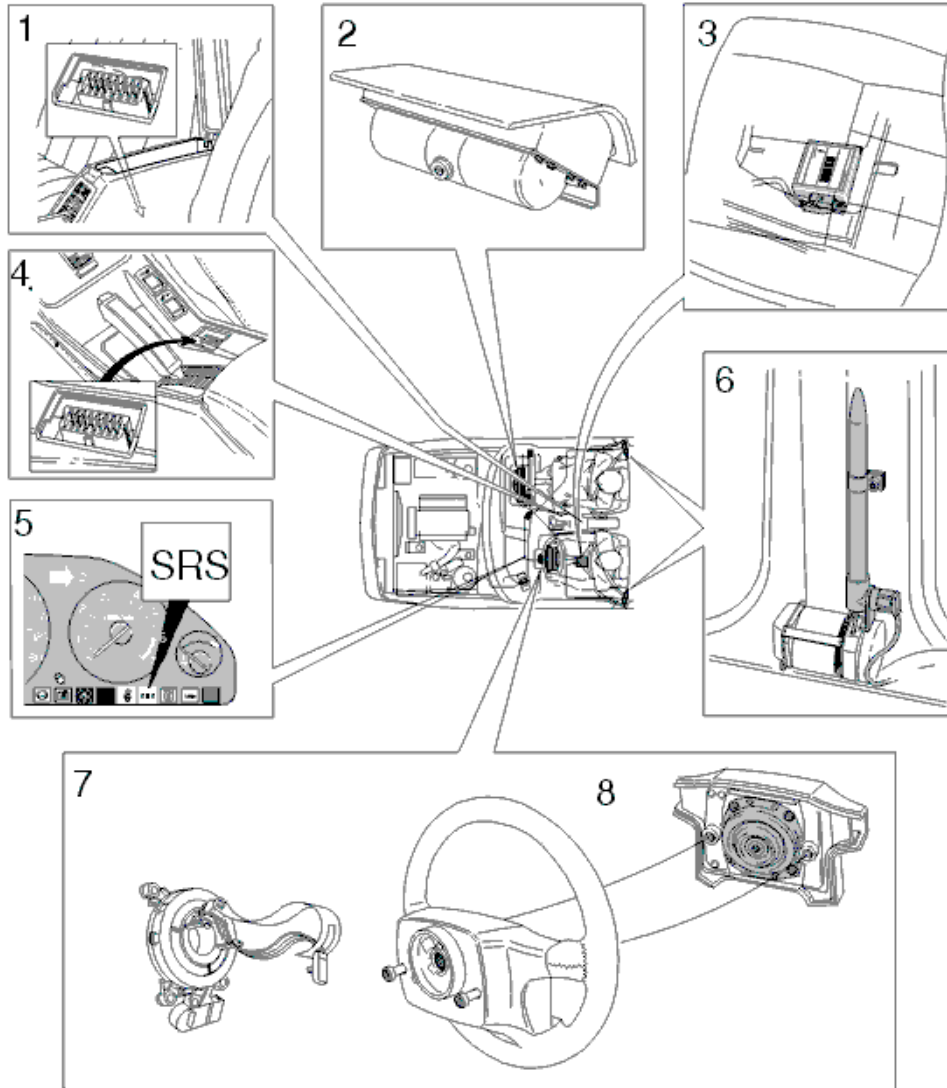

8800839A

SRS components, 940/S90/V90 1997-

- 1: DLC (Data Link Connector)
- 2: Passenger airbag
- 3: SRS sensor module back-up power unit
- 4: OBD II (Data Link Connector) S90/V90
- 5: SRS warning lamp
- 6: Pyrotechnic seat belt pre-tensioner
- 7: Contact Reel
- 8: Driver airbag



8800755A

SIPS components, 960/S90/V90 1996-

- 1: Mechanical Sensor module (**Note:** The sensor is operative even when the power supply is interrupted).
- 2: SRS ignition cable.
- 3: SIPS bag (mechanically activated).

WARNING! Avoid contact with the mechanical sensor.

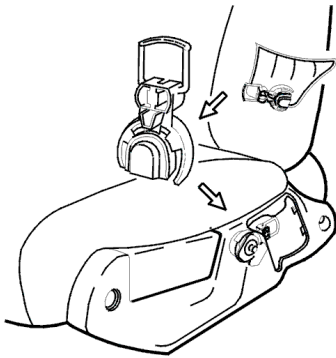

8800842A

Secure the SIPS bag

Before starting service operations, lock the SIPS bag with the transport safety device according to the following:

Remove:

- the panel on the control panel
- the transit safety catch from the inside of the panel.

Install the transit safety catch in the sensor module.

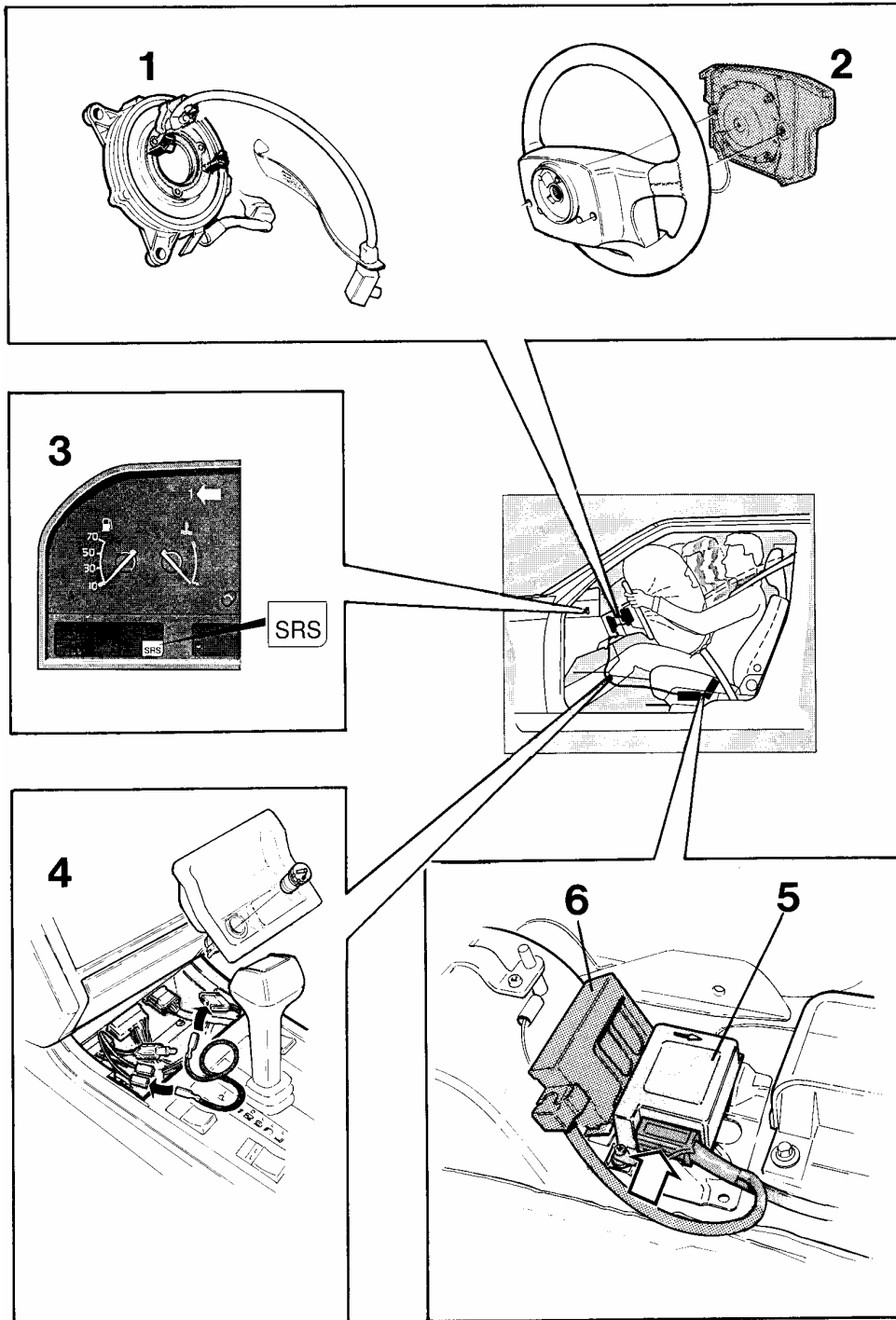

8802546S

SRS components, 850 1992

- 1: Contact Reel
- 2: Driver airbag
- 3: SRS indicator lamp
- 4: Test output
- 5: SRS sensor module
- 6: Back-up power unit

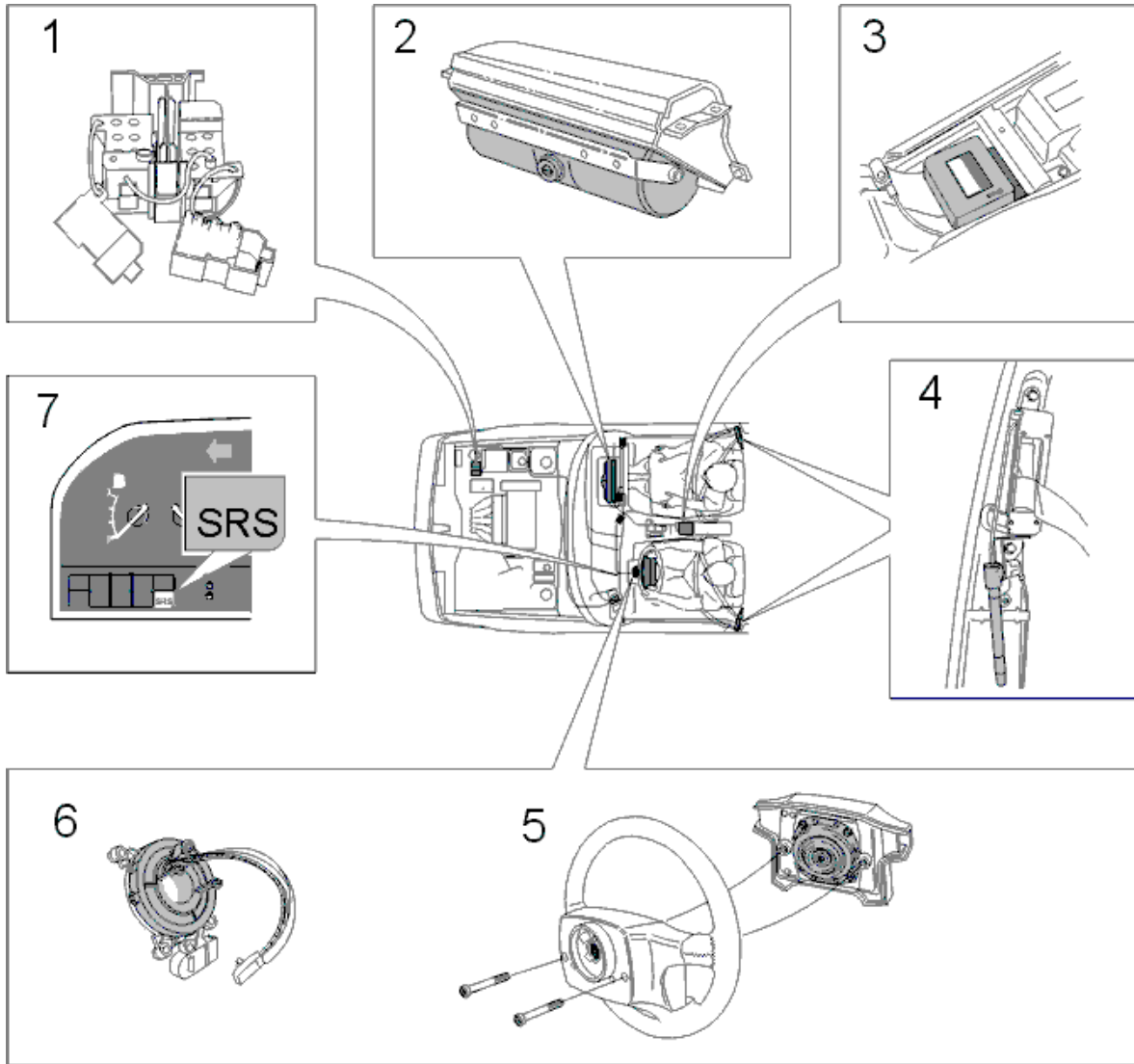

8800366A

SRS components, 850 1993-1995

- 1: DLC (Data link connector)
- 2: Passenger airbag
- 3: SRS sensor module and back-up power unit
- 4: Seat belt pre-tensioner mechanical seat belt pre-tensioner (located at seat belt buckle attachment) up to 1993 inclusive, pyrotechnic from model year 1994).
- 5: Driver airbag
- 6: Contact Reel
- 7: SRS indicator lamp

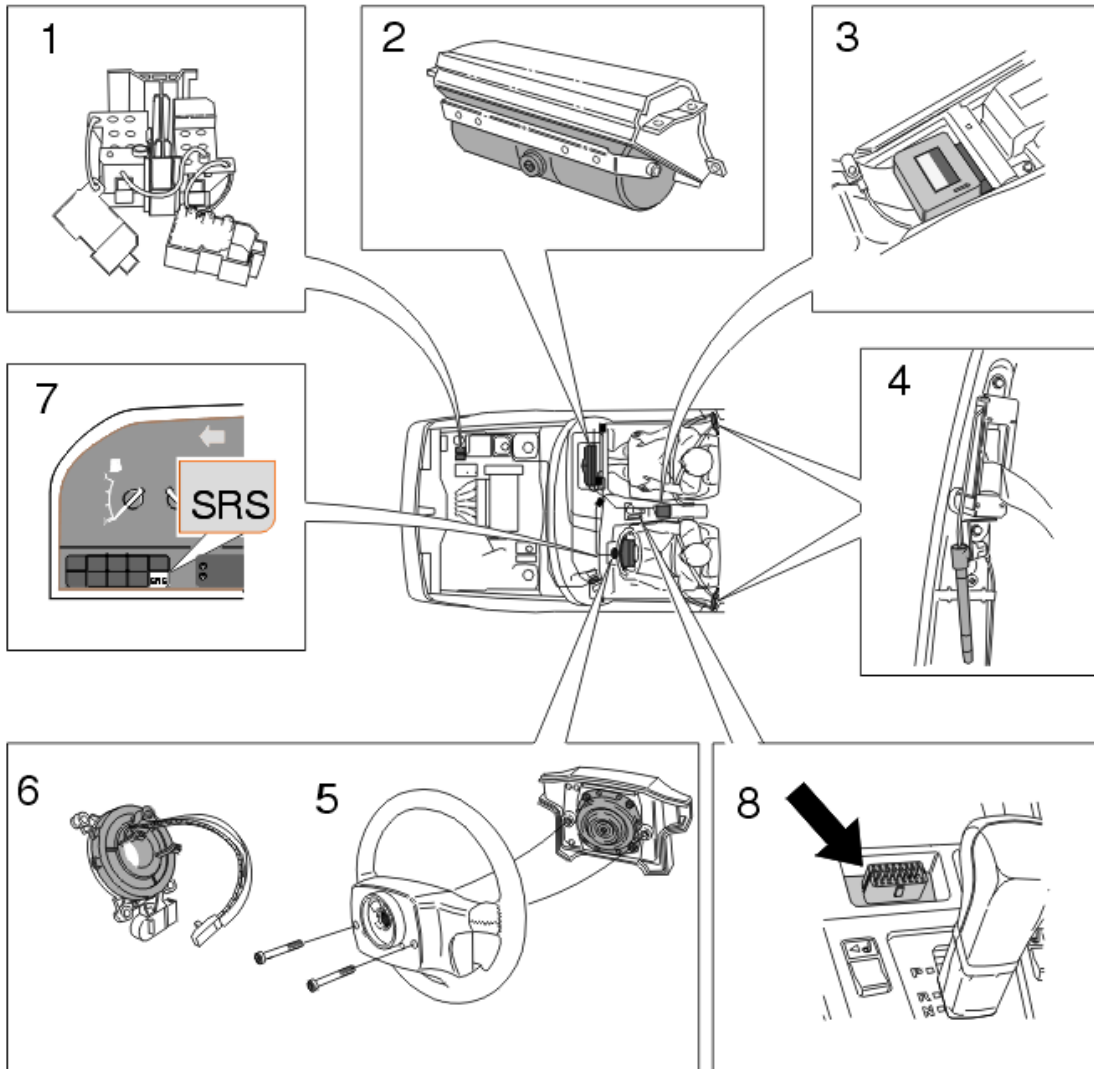

8803056A

SRS components, 850 1996-

- 1: DLC (Data link connector)
- 2: Passenger airbag
- 3: SRS sensor module and back-up power unit
- 4: Seat belt pre-tensioner (mechanical seat belt pre-tensioner (located at seat belt buckle attachment) up to 1993 inclusive, pyrotechnic from model year 1994).
- 5: Driver airbag
- 6: Contact Reel
- 7: SRS indicator lamp
- 8: OBD II (Data link connector)

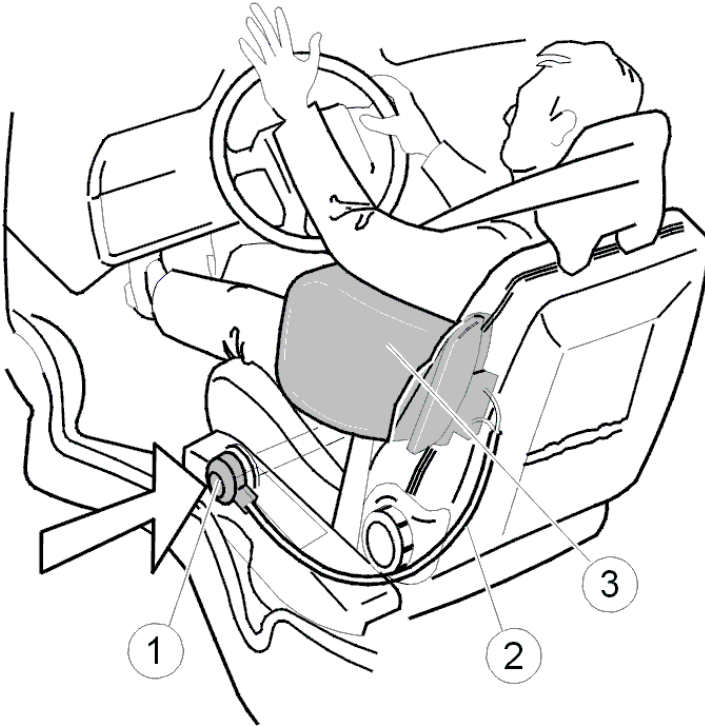

8800505A

SIPS components, 850 1995-1997

- 1: Mechanical Sensor module (**Note:** The sensor is operative even when the power supply is interrupted).
- 2: SRS ignition cable
- 3: SIPS bag (mechanically activated)

WARNING! Avoid contact with the mechanical sensor.

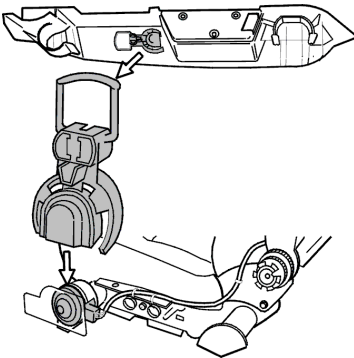

8800507A

Lock SIPS bag

Before starting service operations, lock the SIPS bag with the transport safety device according to the following:

- Lift up seat pocket. Lift the front edge and push the pocket backward.
- Remove transport safety device from its holder inside the seat pocket. (Supplied with all SIPS seats.)
- Attach transport safety device to sensor unit.

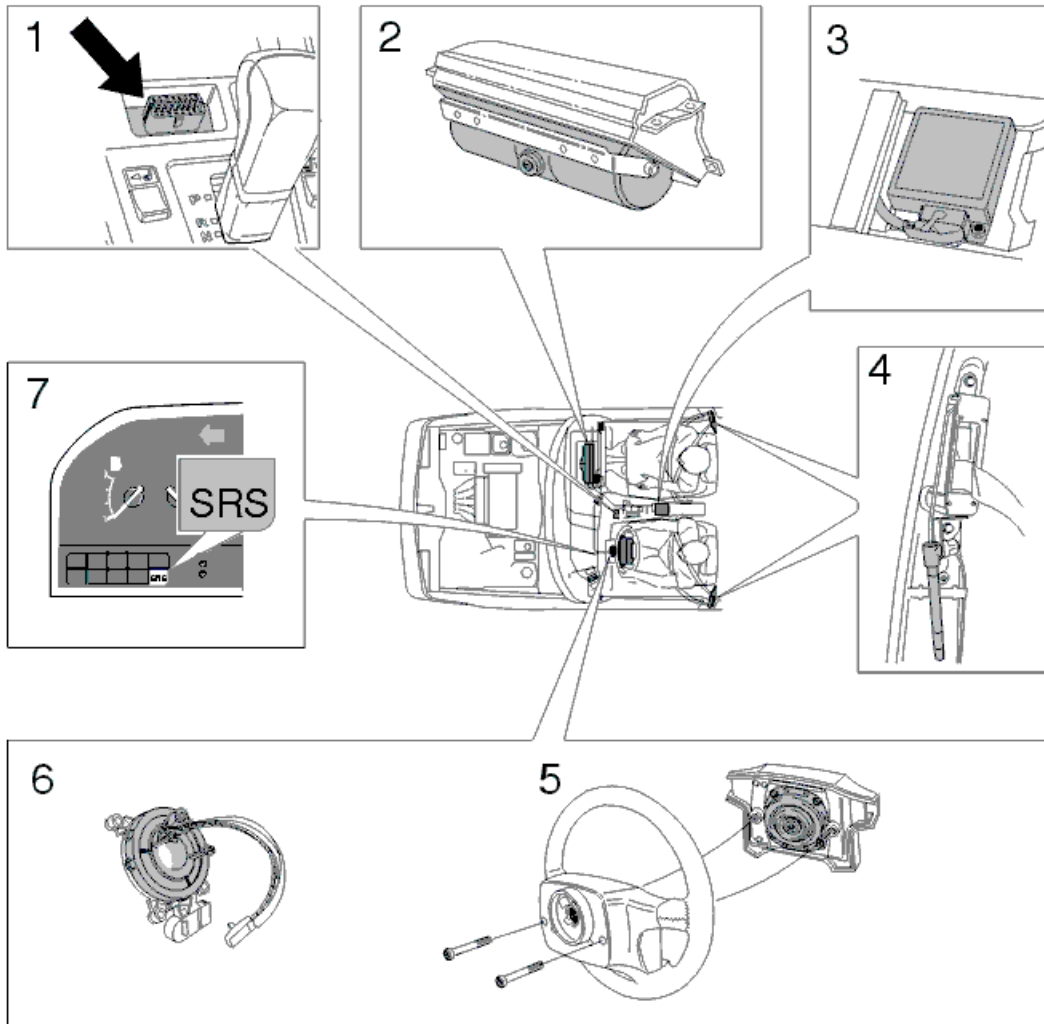

8800809A

SRS components, S70/V70 (-00) 1997-1998

- 1: OBD II (Data link connector)
- 2: Passenger airbag
- 3: SRS sensor module
- 4: Pyrotechnic seat belt pre-tensioner
- 5: Driver airbag
- 6: Contact Reel
- 7: SRS warning lamp

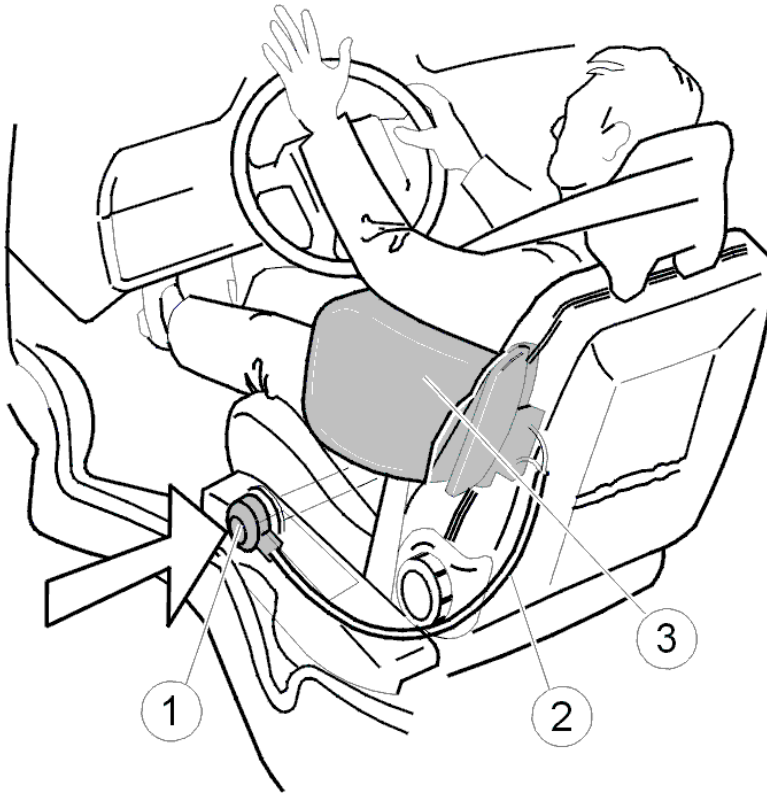

8800505A

SIPS components, S70/V70 (-00) -1998

- 1: Mechanical Sensor module (**Note:** The sensor is operative even when the power supply is interrupted).
- 2: SRS ignition cable
- 3: SIPS bag (mechanically activated)

WARNING! Avoid contact with the mechanical sensor.

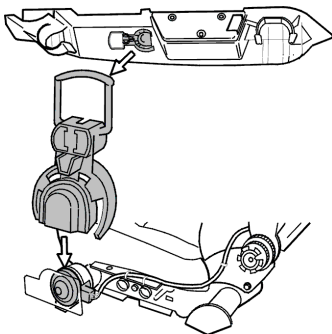

8800507A

Lock SIPS bag

Before starting service operations, lock the SIPS bag with the transport safety device according to the following:

- Lift up seat pocket. Lift the front edge and push the pocket backward.
- Remove transport safety device from its holder inside the seat pocket. (Supplied with all SIPS seats.)
- Attach transport safety device to sensor unit.

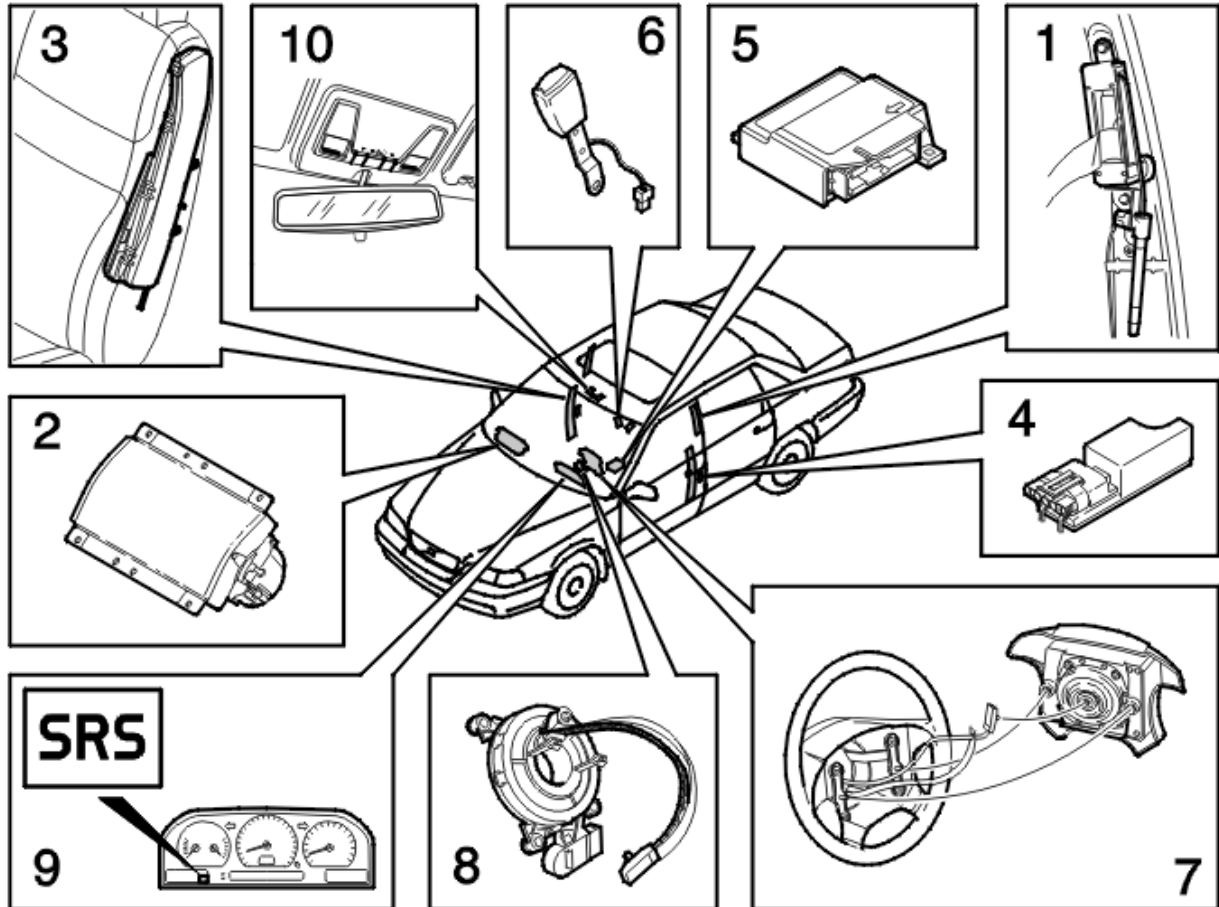

8803058B

SRS components, S70/V70 (-00) 1999-2000

- 1: Pyrotechnic seat belt pre-tensioner
- 2: Passenger airbag
- 3: SIPS bag (electrically activated)
- 4: Side impact sensor
- 5: SRS sensor module
- 6: Seat belt buckle
- 7: Driver airbag
- 8: Contact Reel
- 9: SRS warning lamp
- 10: Seat belt reminder

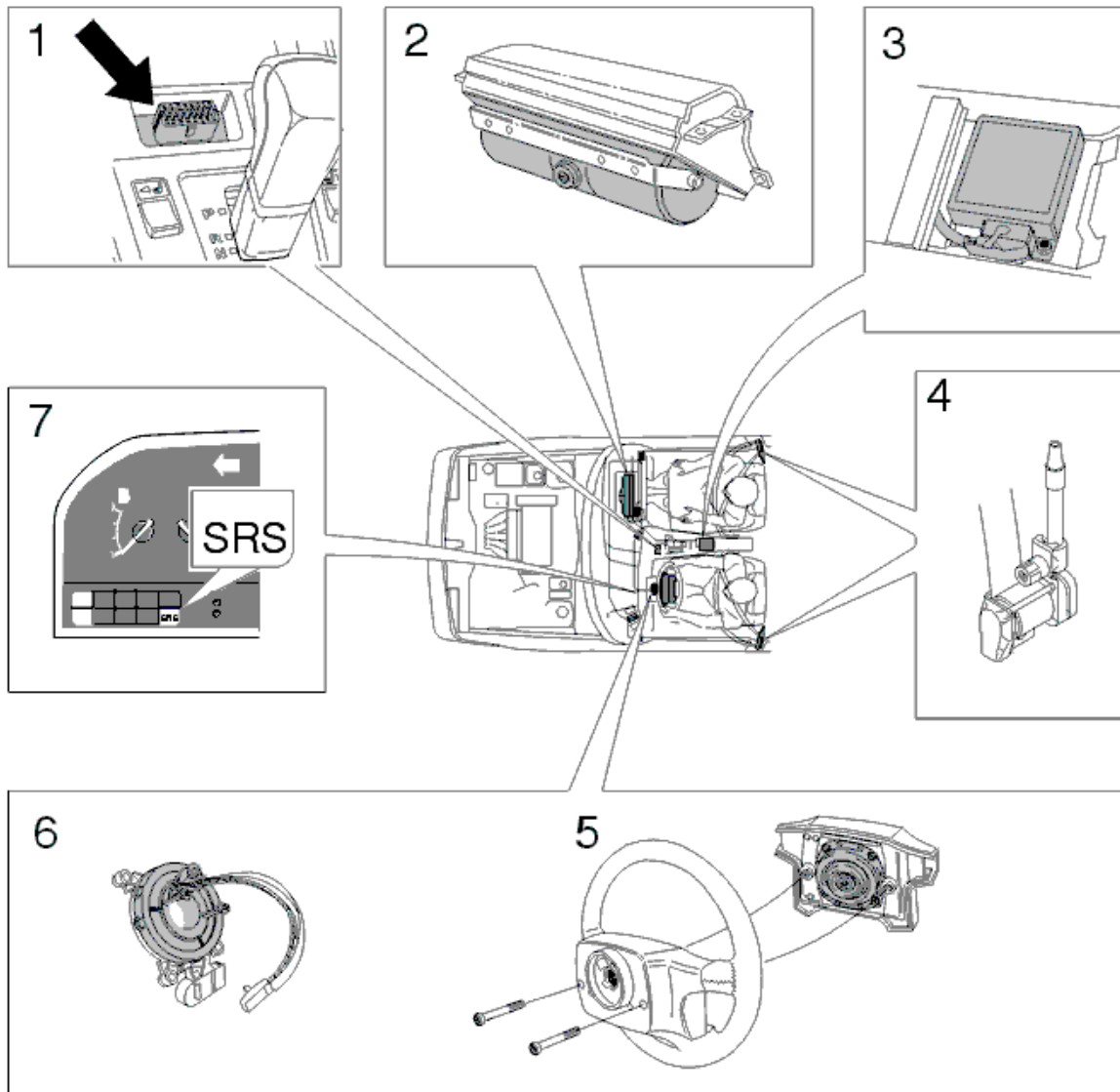

8802691A

SRS components, C70 Coupé 1998

- 1: OBD II (Data link connector)
- 2: Passenger airbag
- 3: SRS sensor module
- 4: Pyrotechnic seat belt pre-tensioner
- 5: Driver airbag
- 6: Contact Reel
- 7: SRS warning lamp



8800502A

SIPS components, C70 Coupé 1998

- 1: Sensor module (**Note:** The sensor is operative even when the power supply is interrupted).
- 2: SRS ignition cable
- 3: SIPS bag (mechanically activated)

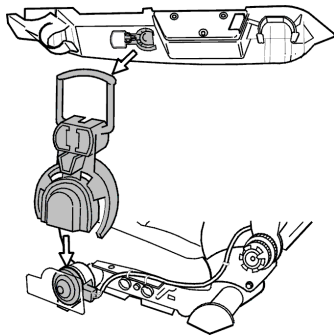
WARNING! Avoid contact with the mechanical sensor.

8800507A

Lock SIPS bag

Before starting service operations, lock the SIPS bag with the transport safety device according to the following:

- Lift up seat pocket. Lift the front edge and push the pocket backward.
- Remove transport safety device from its holder inside the seat pocket. (Supplied with all SIPS seats.)
- Attach transport safety device to sensor unit.

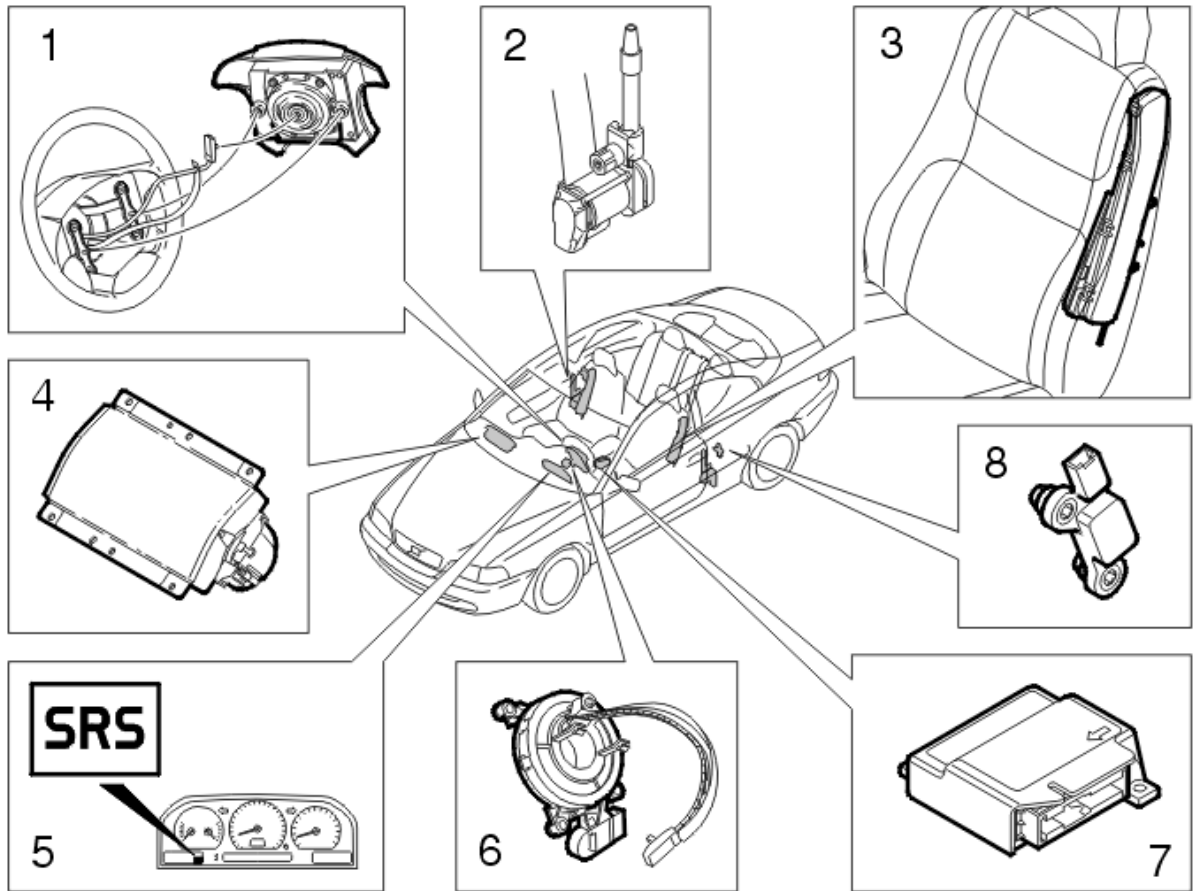

8803057A

SRS components, C70 Coupé 1999-

- 1: Driver airbag
- 2: Pyrotechnic seat belt with seat belt pre-tensioner
- 3: SIPS bag
- 4: Passenger airbag
- 5: SRS warning lamp
- 6: Contact Reel
- 7: SRS sensor module
- 8: Side impact sensors

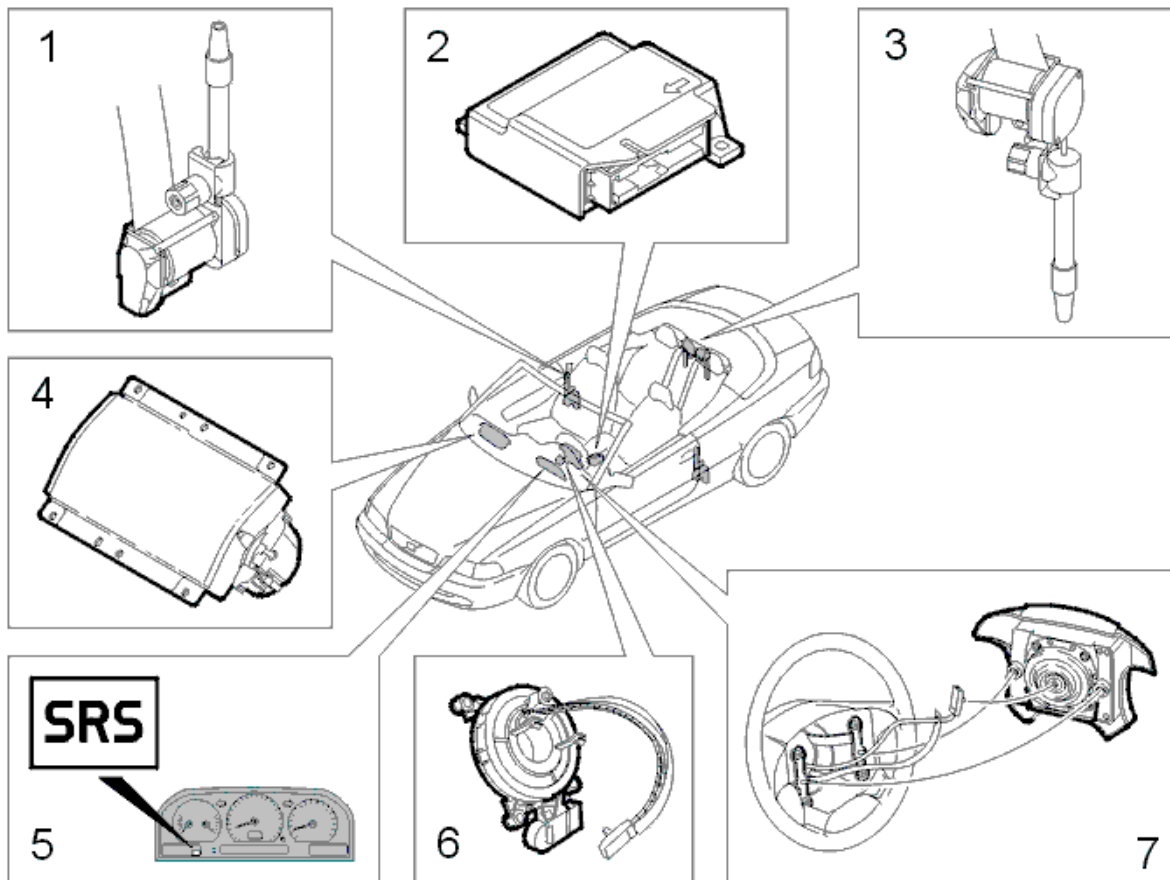

8801791A

SRS components, C70 Convertible 1998

- 1: Front pyrotechnical seat belt tensioner
- 2: SRS control module
- 3: Rear pyrotechnical seat belt tensioner
- 4: Passenger airbag module
- 5: SRS indicator lamp
- 6: Contact Reel
- 7: Steering wheel module

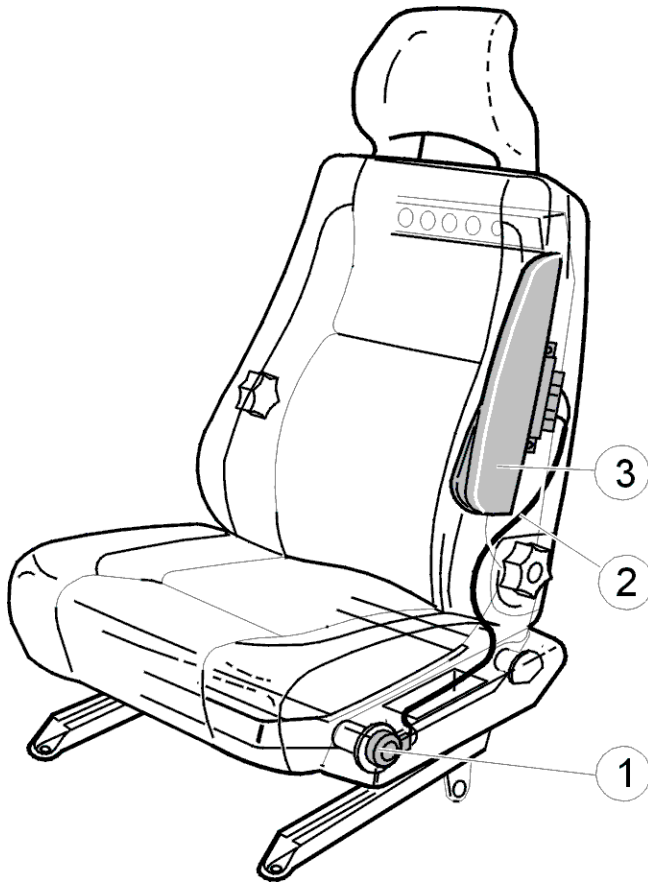

8800502A

SIPS components, C70 Convertible 1998

- 1: Sensor module (**Note:** The sensor is operative even when the power supply is interrupted).
- 2: SRS ignition cable
- 3: SIPS bag (mechanically activated)

WARNING! Avoid contact with the mechanical sensor.

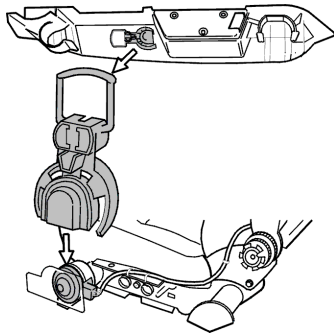

8800507A

Lock SIPS bag

Before starting service operations, lock the SIPS bag with the transport safety device according to the following:

- Lift up seat pocket. Lift the front edge and push the pocket backward.
- Remove transport safety device from its holder inside the seat pocket. (Supplied with all SIPS seats.)
- Attach transport safety device to sensor unit.

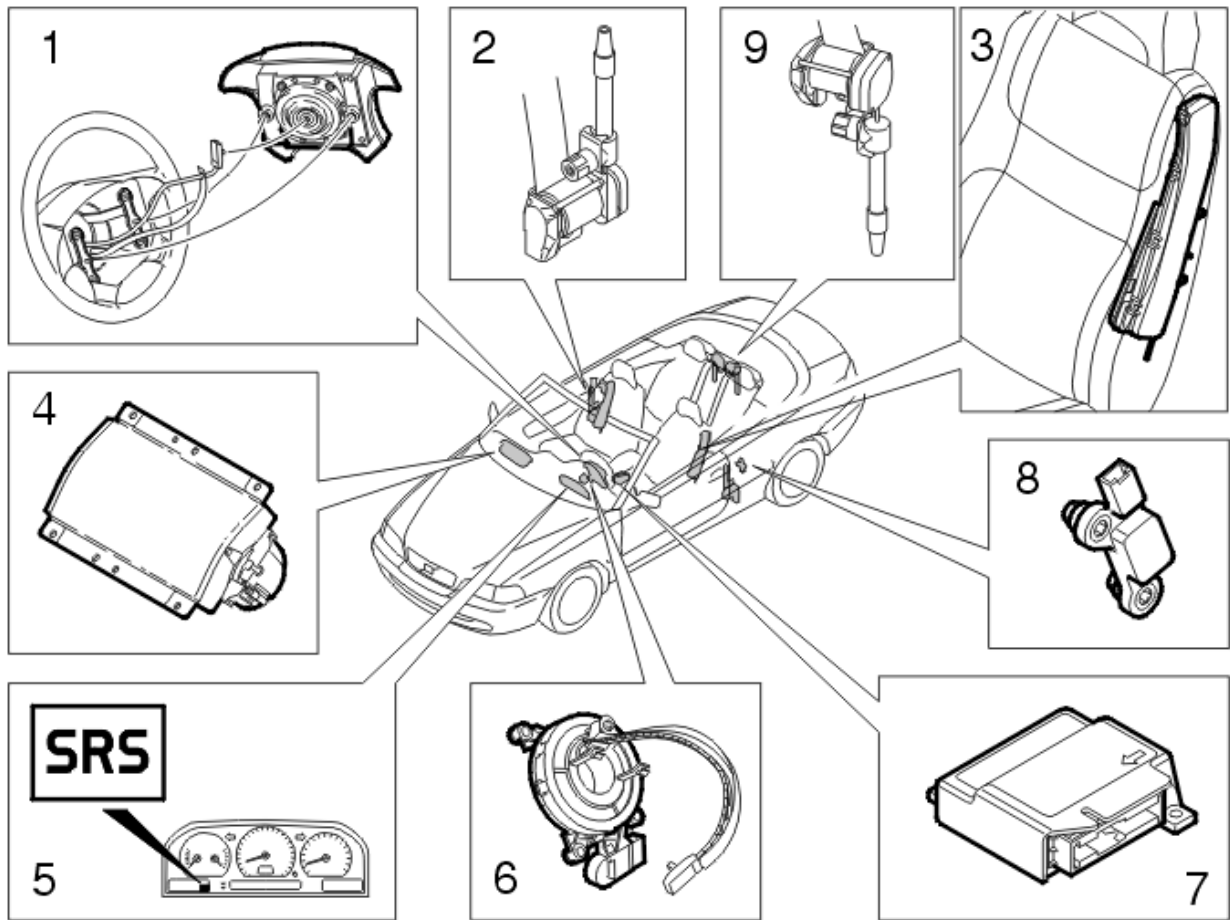

8803059A

SRS components, C70 Convertible 1999-

- 1: Driver airbag
- 2: Pyrotechnic seat belt with seat belt pre-tensioner, front seats
- 3: SIPS bag (electrically activated)
- 4: Passenger airbag
- 5: SRS warning lamp
- 6: Contact Reel
- 7: SRS sensor module
- 8: Electric side impact sensor (from MY 2000)
- 9: Pyrotechnic seat belt with seat belt pre-tensioner, rear seat

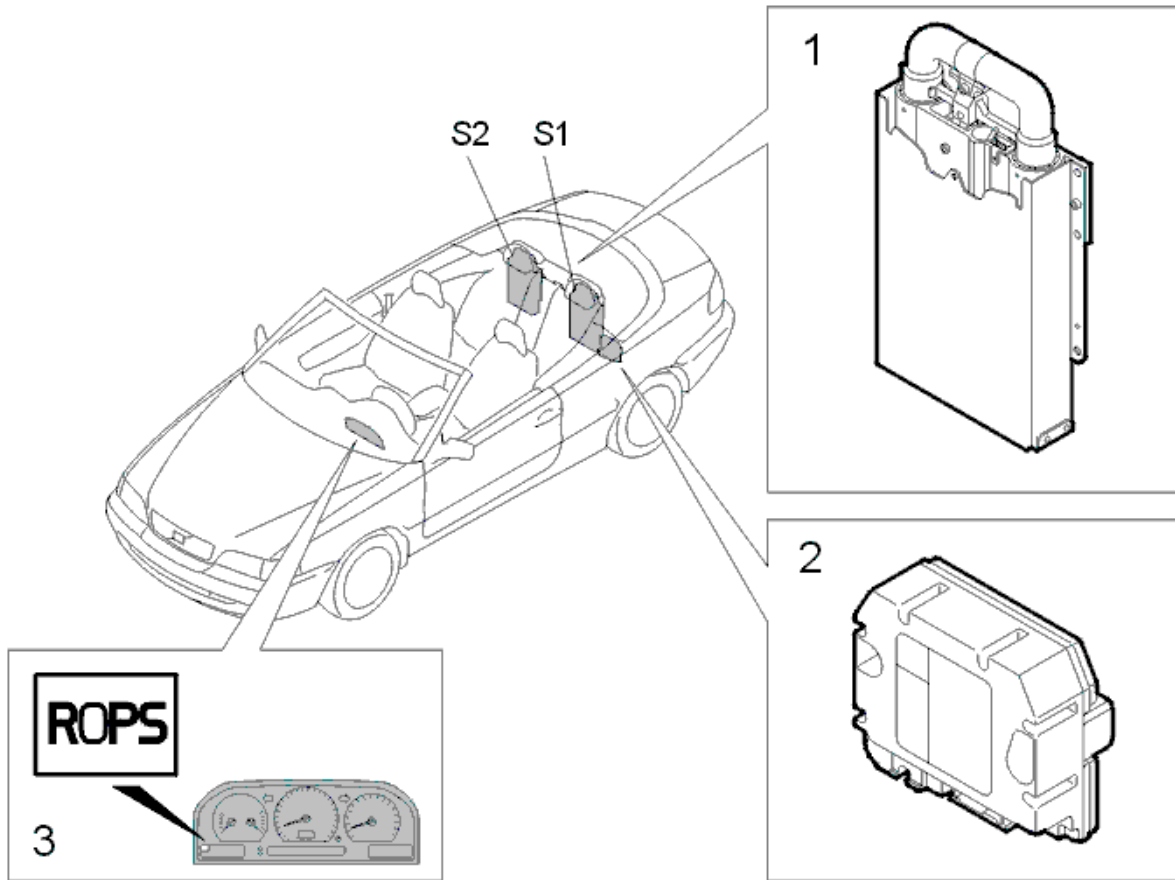

8801792A

ROPS components, C70 Convertible 1998-2000

- 1: ROPS cassette
- 2: ROPS control module
- 3: ROPS indicator lamp

ROPS is activated by the sensor behind the head restraint. This sensor monitors the tilt of the car. ROPS is deployed by a built in coil spring and contains no pyrotechnic material.

WARNING! Do not work within the ROPS' radius of action when the vehicle is being tilted.

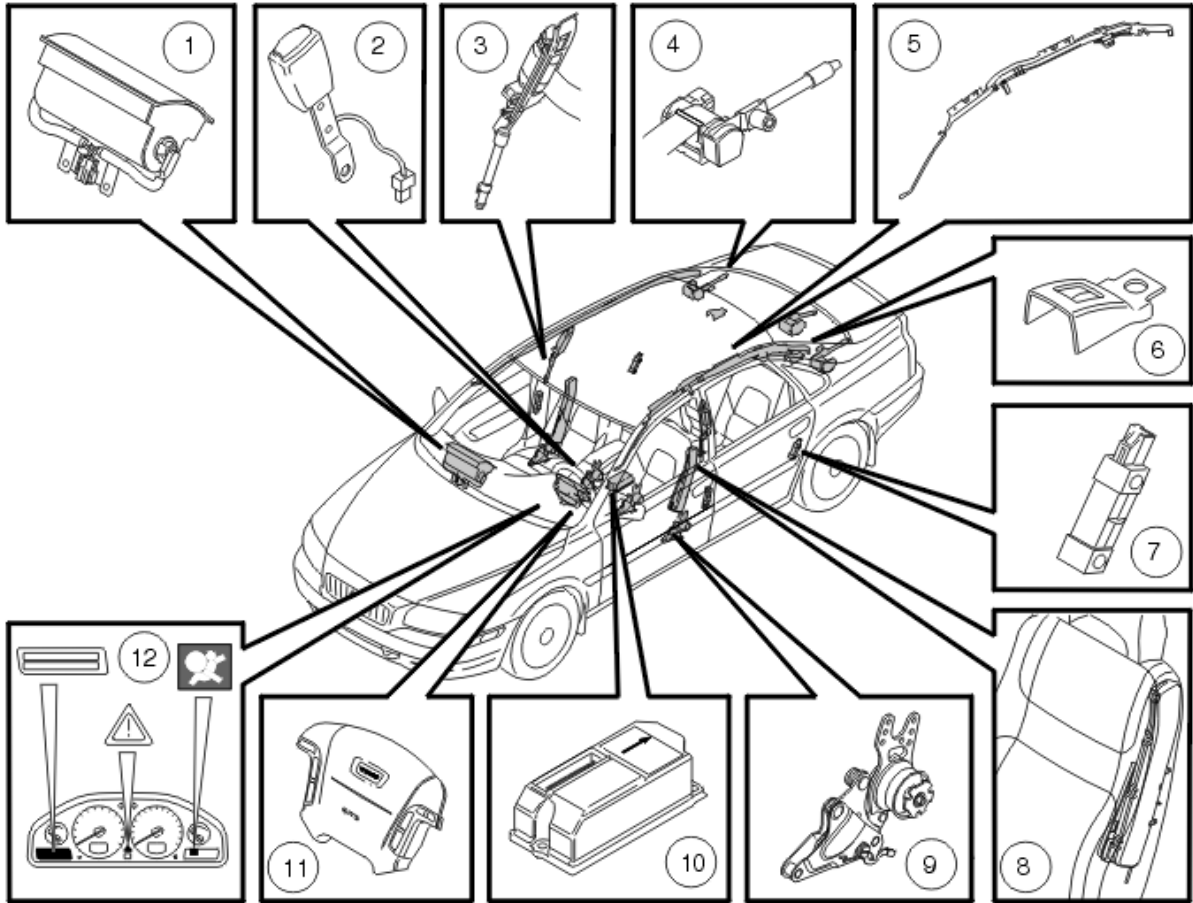

8803060D

SRS components, S80 1999-

- 1: Passenger airbag
- 2: Seat belt buckle
- 3: Seat belt with pyrotechnic seat belt pre-tensioner, front seat
- 4: Seat belt with pyrotechnic seat belt pre-tensioner, rear seat
- 5: IC airbag
- 6: Child seat anchorage for child seats (certain models only)
- 7: Electric sensor in the B and C-pillars
- 8: SIPS bag
- 9: WHIPS
- 10: SRS sensor module
- 11: Driver airbag
- 12: Combined instrument panel

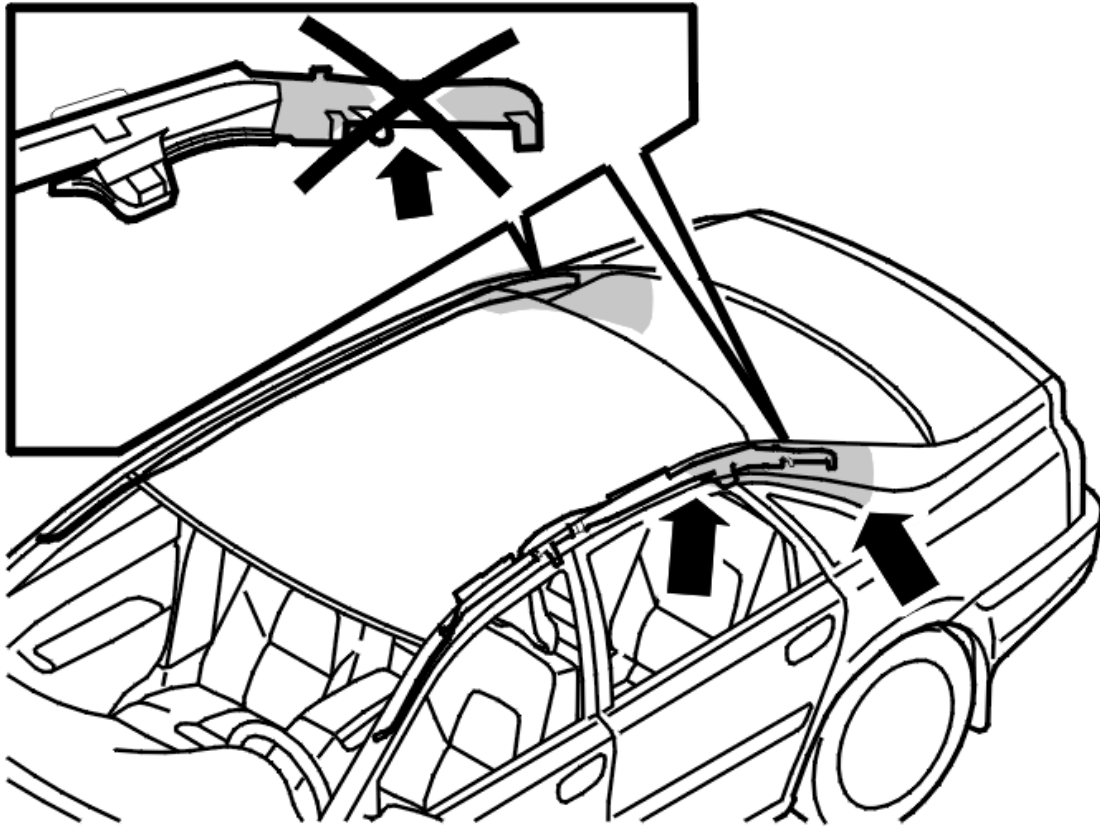

8802995R

Inflatable curtains, S80 1999-

Important! If the roof needs to be cut open, avoid cutting the gas tubes (placed between the arrows) for the inflatable curtain system.

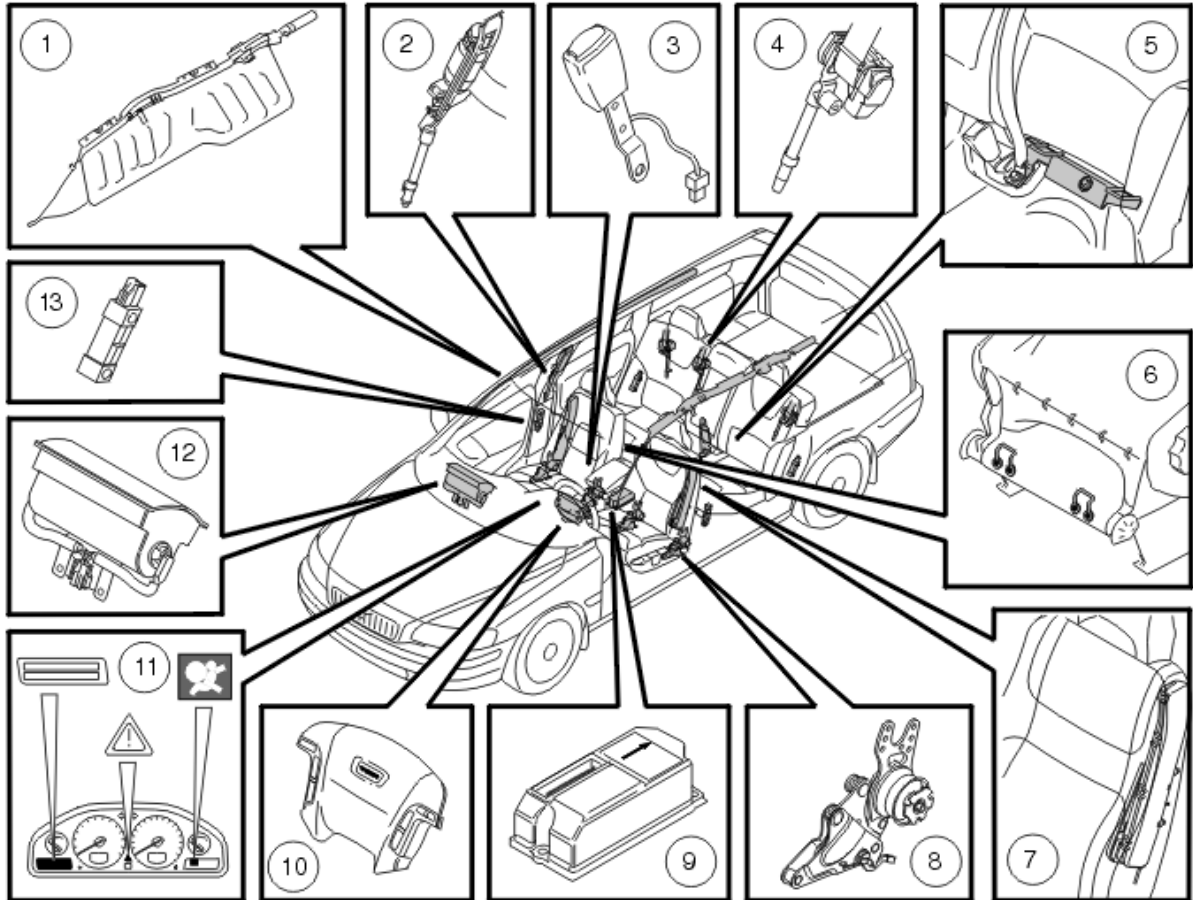

8803061M

SRS components, V70 (01-)/V70 XC (01-)/XC70

- 1: IC airbag
- 2: Seat belt with pyrotechnic seat belt pre-tensioner, front seat
- 3: Seat belt buckle
- 4: Seat belt with pyrotechnic seat belt per-tensioner, rear seat
- 5: Child seat anchorage for child seats (certain models only)
- 6: Child seat anchorage for child seats (certain models only)
- 7: SIPS bag
- 8: WHIPS
- 9: SRS sensor module
- 10: Driver airbag
- 11: Combined instrument panel
- 12: Passenger airbag
- 13: Sensor in the B and C-pillars

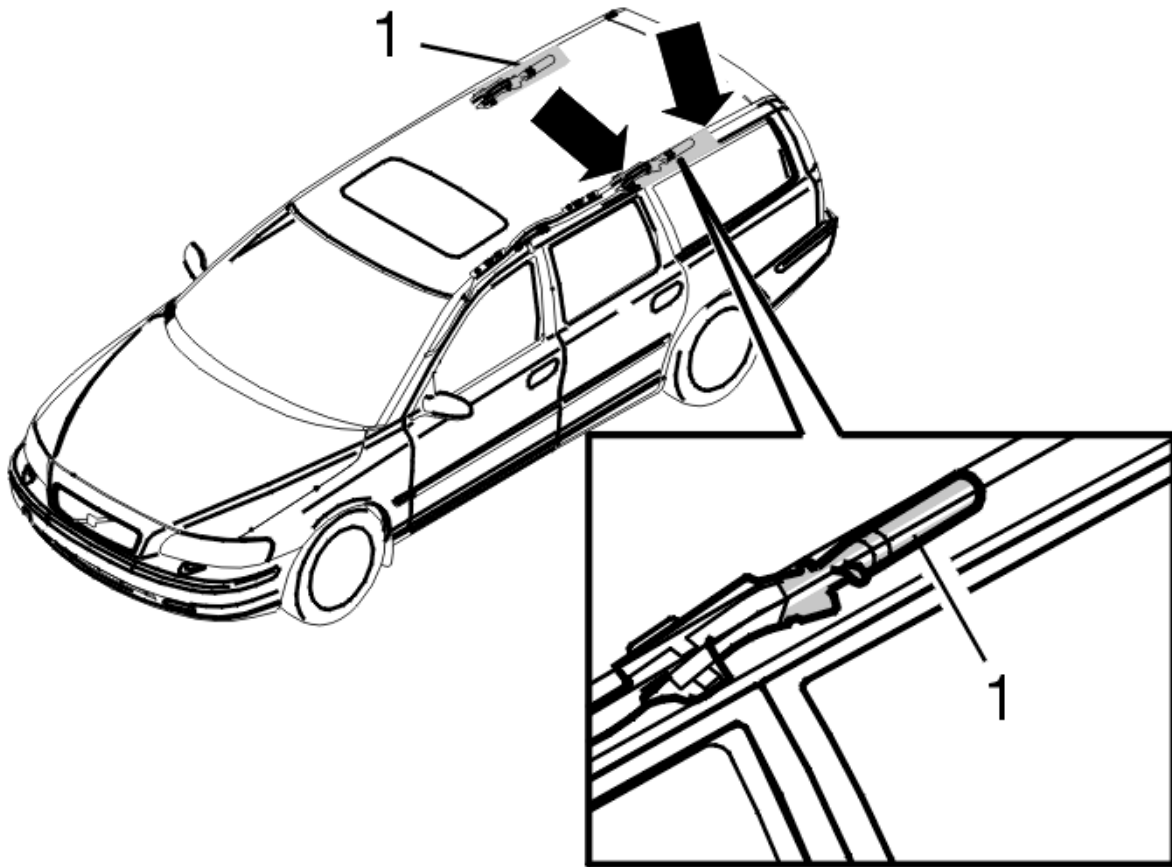

8802668M

Inflatable curtains, V70 (01-)/V70 XC (01-) (USA) and XC70

Important! For vehicles with inflatable curtains, if the roof needs to be cut open, avoid cutting the gas tubes (1) (placed between the arrows) for the inflatable curtain system.

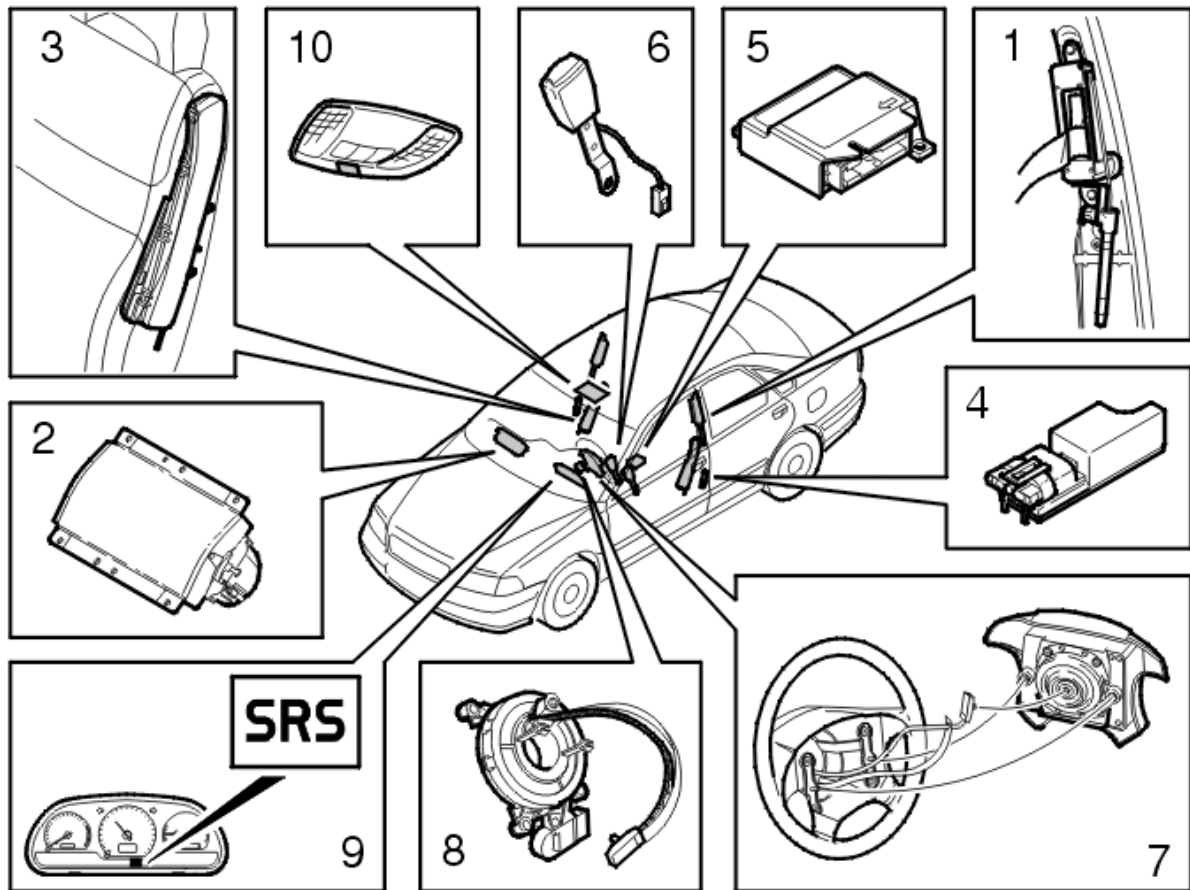

8803062G

SRS components, S40 (-04)/V40 2000

- 1: Pyrotechnic seat belt pre-tensioner
- 2: Passenger airbag
- 3: SIPS bag (electrically activated)
- 4: Side impact sensor
- 5: SRS sensor module
- 6: Seat belt buckle
- 7: Driver airbag
- 8: Contact Reel
- 9: SRS warning lamp
- 10: Seat belt reminder

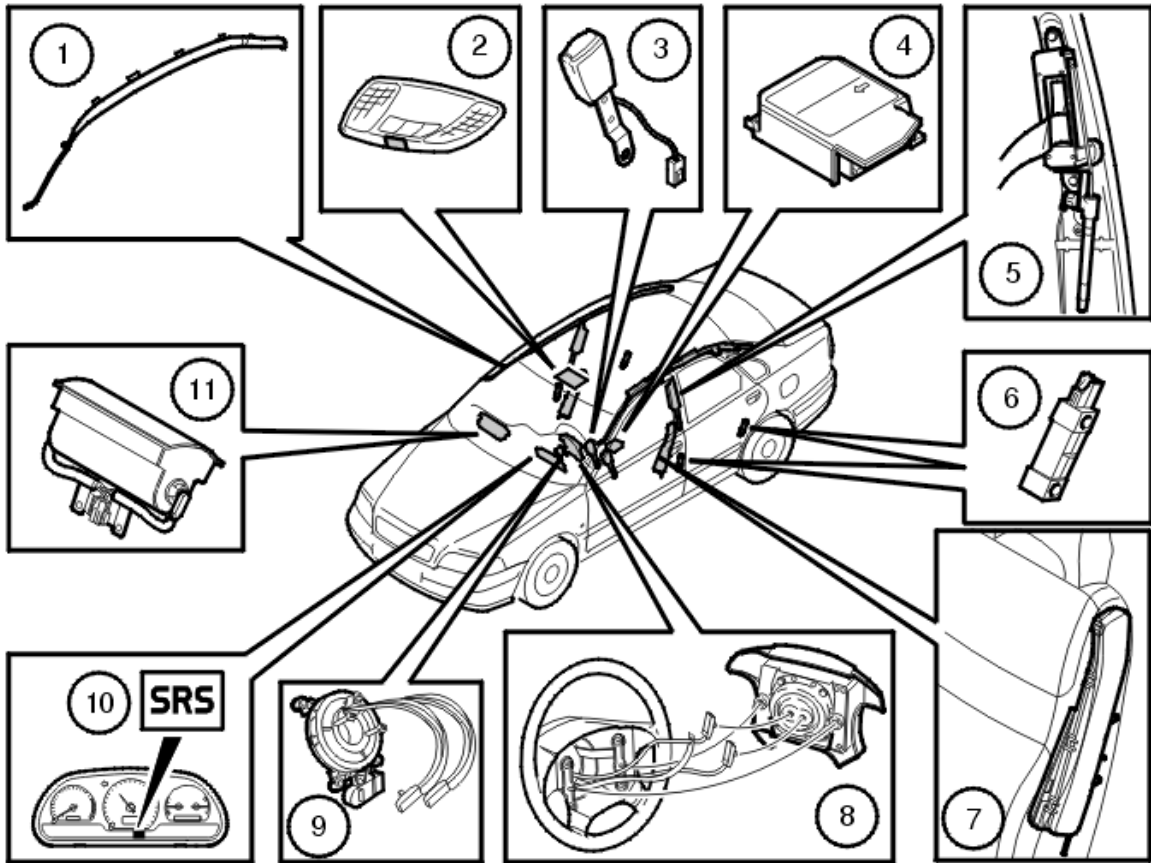

8803063G

SRS components, S40 (-04)/V40 2001

- 1: IC airbag
- 2: Seatbelt reminder light
- 3: Seat belt buckle with sensor
- 4: SRS sensor module
- 5: Seat belt with pyrotechnic seat belt pre-tensioner
- 6: Sensor in the B and C-pillars
- 7: SIPS bag
- 8: Driver airbag
- 9: Contact Reel
- 10: SRS warning lamp
- 11: Passenger airbag

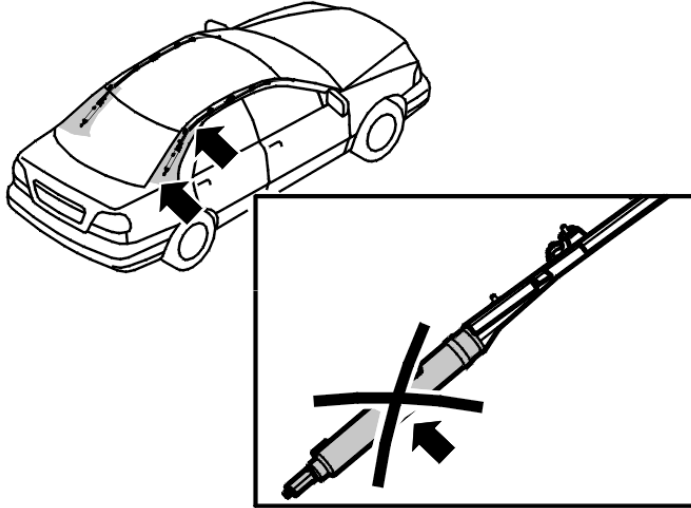

8802671G

Inflatable curtains, S40 (-04) 2001-

Important! For vehicles with inflatable curtains, if the roof needs to be cut open, avoid cutting the gas tubes (placed between the arrows) for the inflatable curtain system.

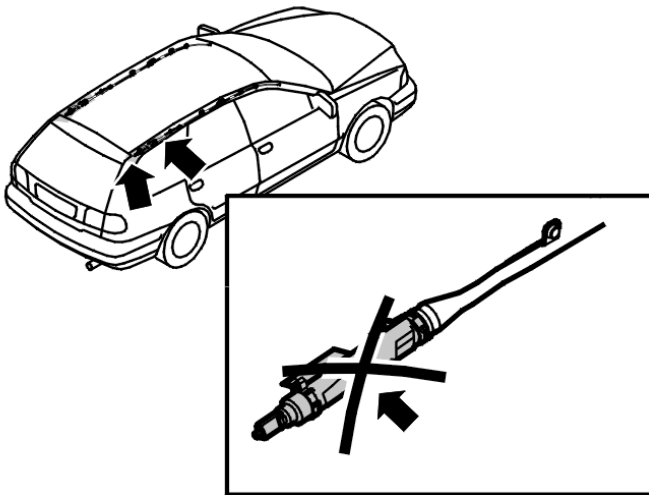

8802672G

Inflatable curtains, V40 2001-

Important! For vehicles with inflatable curtains, if the roof needs to be cut open, avoid cutting the gas tubes (placed between the arrows) for the inflatable curtain system.

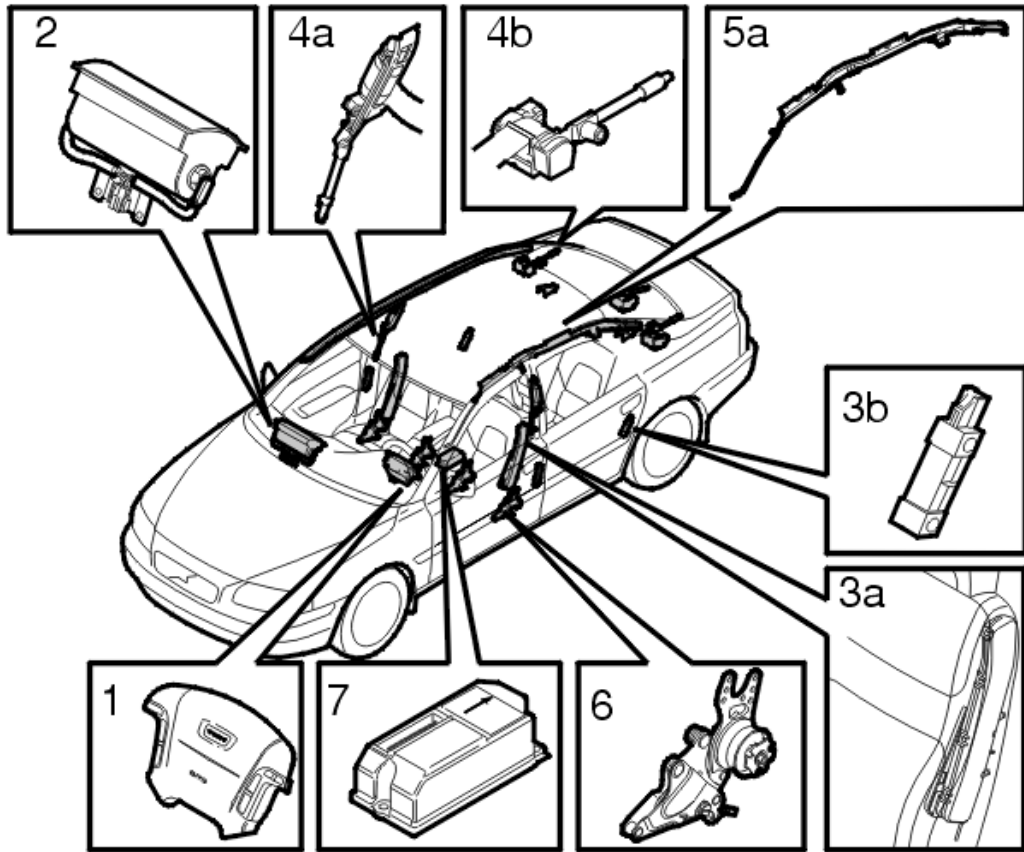

8803064D

SRS components, S60 2001-

- 1: Driver airbag
- 2: Passenger airbag
- 3: a) SIPS bag
b) Sensor in the B and C-pillars
- 4: a) Seat belt with pyrotechnic seat belt pre-tensioner, front seats
b) Seat belt with pyrotechnic seat belt pre-tensioner, rear seats
- 5: IC airbag
- 6: WHIPS
- 7: SRS sensor module

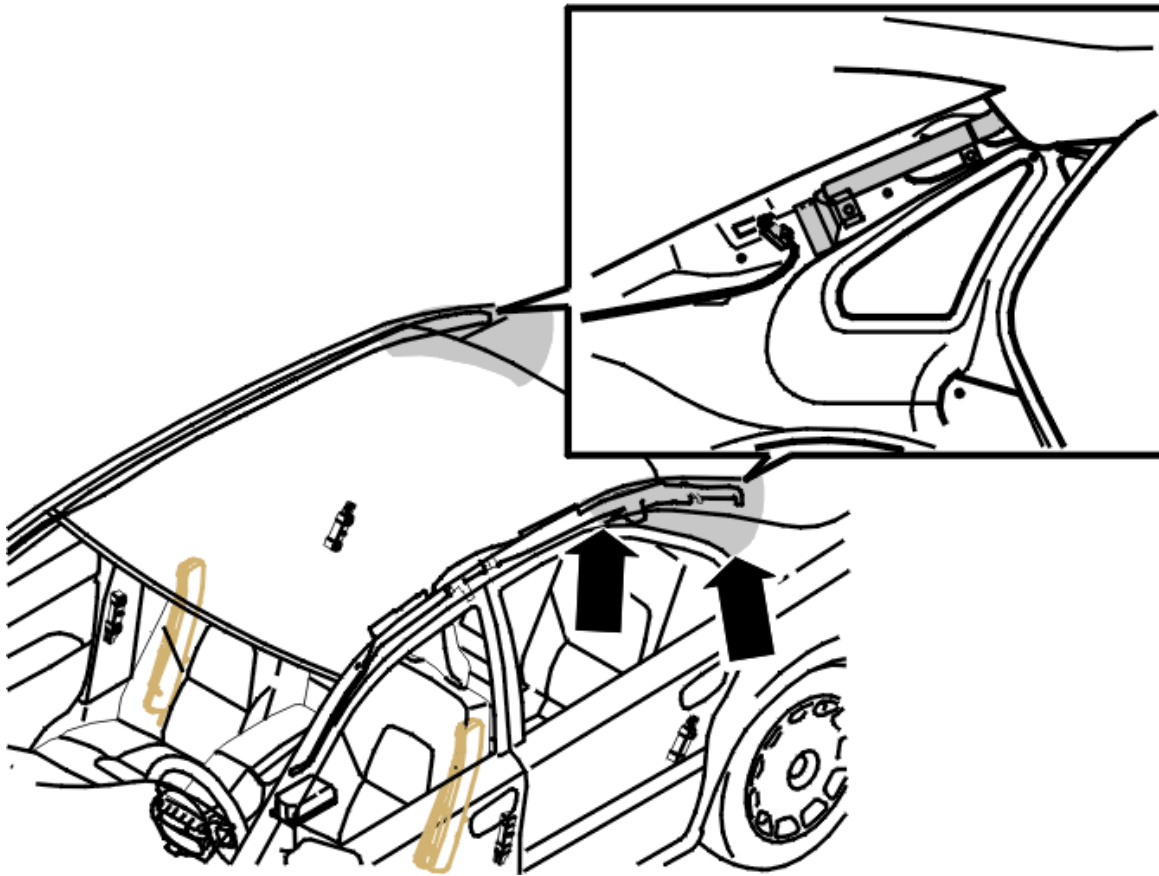

8802676M

Inflatable curtains, S60

Important! For vehicles with inflatable curtains, if the roof needs to be cut open, avoid cutting the gas tubes (placed between the arrows) for the inflatable curtain system.

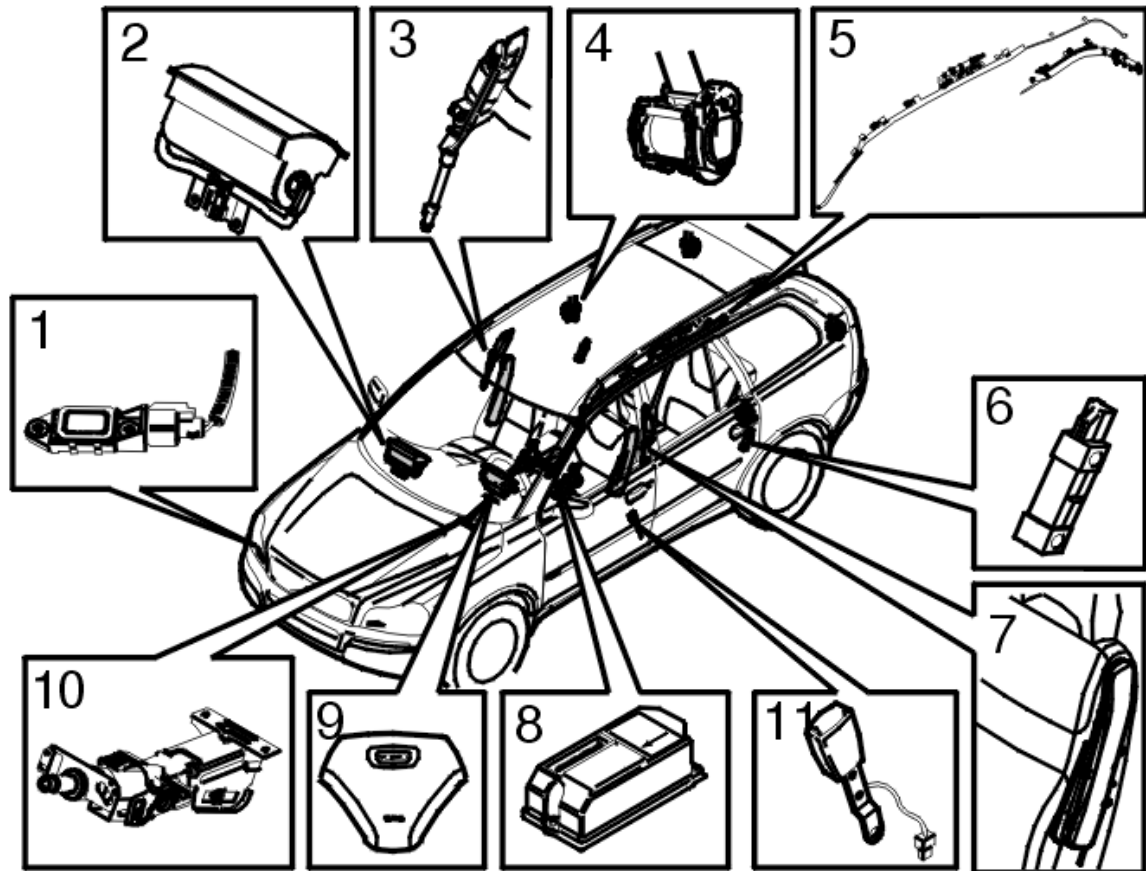

8803069R

SRS components, XC90

- 1: Frontal collision sensors, left and right, front
- 2: Passenger airbag
- 3: Seat belt with pyrotechnic seat belt pre-tensioner, front seats
- 4: Seat belt with pyrotechnic seat belt pre-tensioner, 2nd row. Seat belt pre-tensioners, 3rd row (7 seater models only).
- 5: IC airbag, front and (rear, 7 seater models only)
- 6: Sensor in the B and C-pillars, left and right
- 7: SIPS bag, left and right, front
- 8: SRS sensor module
- 9: Driver airbag
- 10: Steering column
- 11: Seat belt buckle, left and right, front

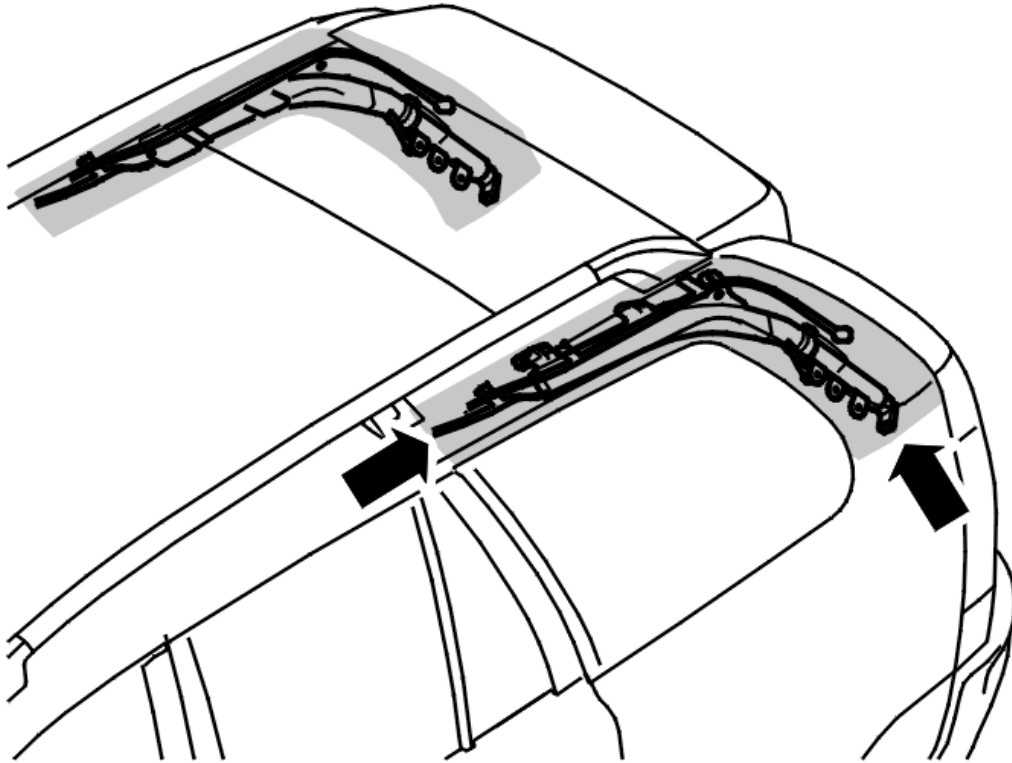

8802995R

Inflatable curtains, XC90

Important! For vehicles with inflatable curtains, if the roof needs to be cut open, avoid cutting the gas tubes (placed between the arrows) for the inflatable curtain system.

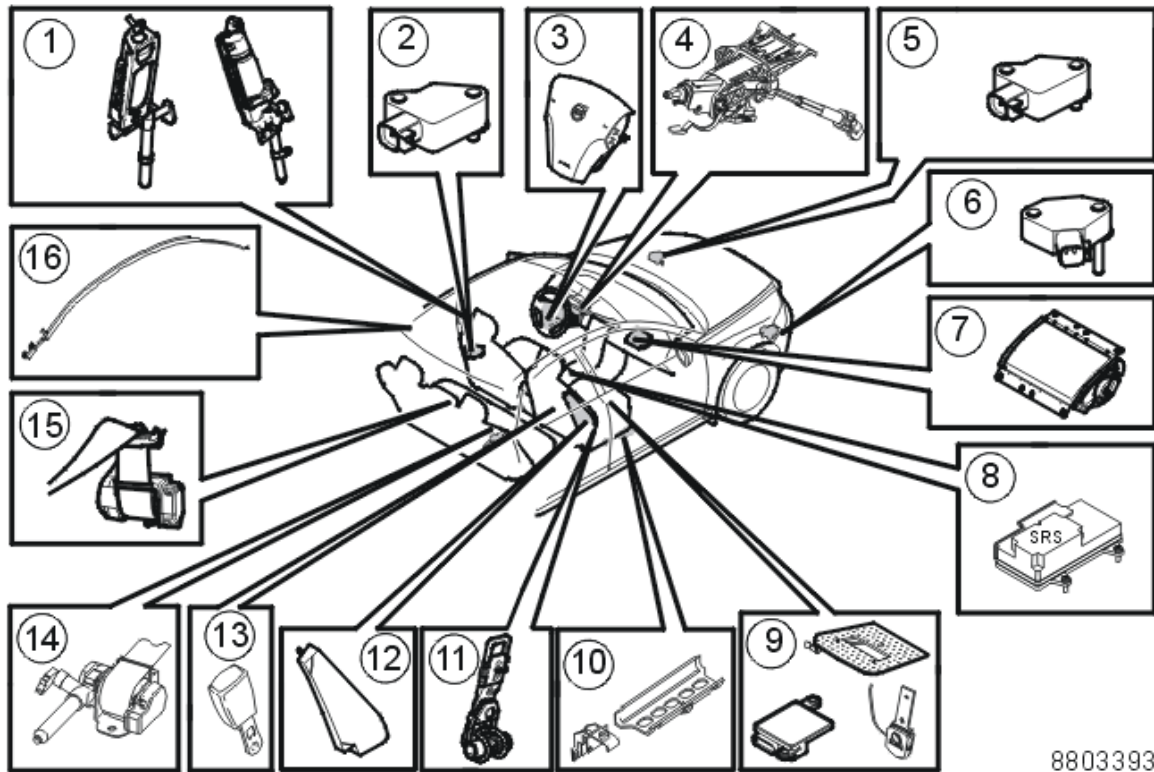

8803393j

SRS components, S40 (04.5-)/V50 (USA/CDN) 2005-

- 1: Adaptive seat belt pre-tensioner, left and right, front
- 2: Sensor in the B- and C-pillars, left and right
- 3: Driver airbag
- 4: Collapsible steering column
- 5: Sensor, left, front
- 6: Sensor, right, front
- 7: Passenger airbag
- 8: SRS sensor module
- 9: OWS
- 10: Set track sensor, left and right, front
- 11: Anchor plate load limiter, left and right, front
- 12: SIPS airbag, left and right, front
- 13: Seat belt buckle, left and right, front
- 14: Seat belt with pyrotechnic seat belt pre-tensioner, left and right, rear
- 15: Seat belt, rear, center (non pyrotechnic)
- 16: IC airbag, left and right

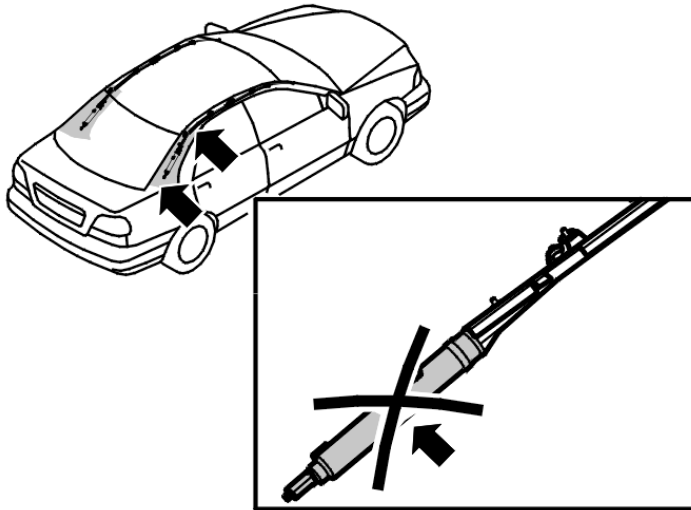

8802671G

Inflatable curtains, S40 2004.5-

Important! For vehicles with inflatable curtains, if the roof needs to be cut open, avoid cutting the gas tubes (placed between the arrows) for the inflatable curtain system.

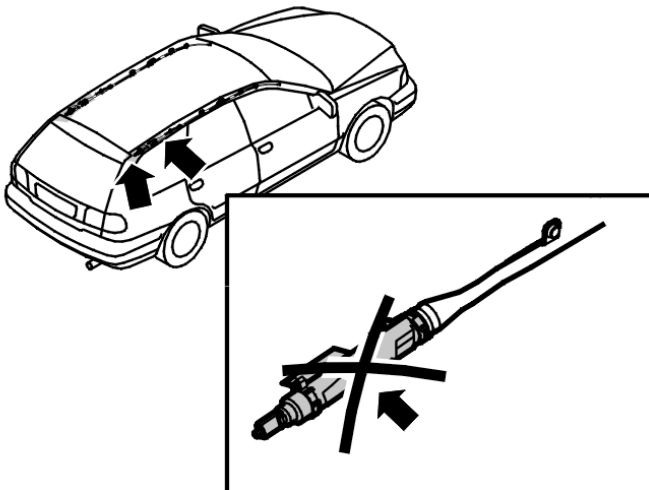

8802672G

Inflatable curtains, V50 2005-

Important! For vehicles with inflatable curtains, if the roof needs to be cut open, avoid cutting the gas tubes (placed between the arrows) for the inflatable curtain system.

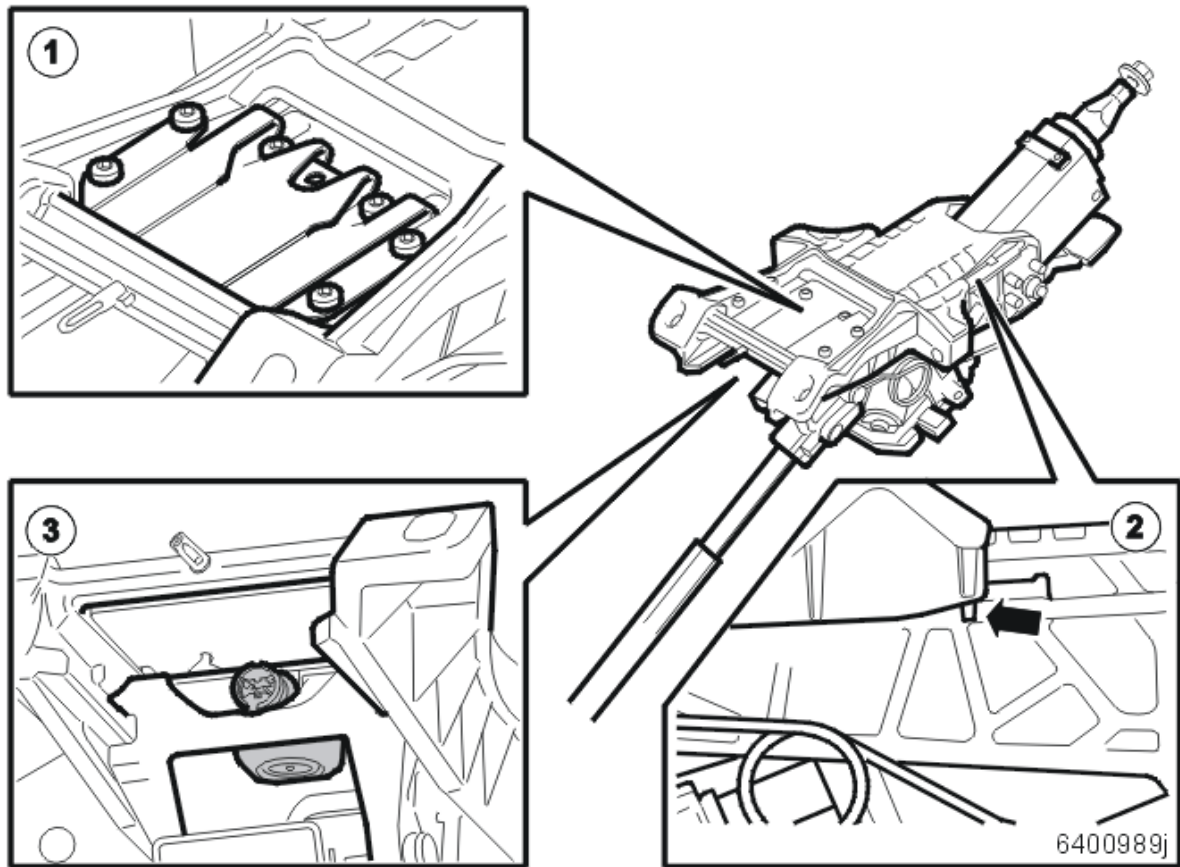

SRS components, S40 (04.5-)/V50 (USA/CDN) 2005-

- 1: Deformation element
- 2: Marking
- 3: Igniter

Collapsible steering column (USA/CDN)

- When the collision protection system in the collapsible steering column is activated, a pin deploys enabling the steering column to be adjusted for length. If the level of a frontal collision exceeds a certain level, the steering wheel is pressed in further towards the dashboard than if the steering column was rigid.
- Control of the vehicle is not affected by the triggered pin. A pyrotechnic charge causes the pin to deploy and is positioned in the center of the steering column. The collision protection system in the collapsible steering column only operates if the driver has his/her seat belt fastened and when the air bag is deployed.
- The steering column has a mark which indicates that the steering column has collapsed.

Location of decals showing the existing airbag system in the car

Decals

There are decals both inside and outside the vehicle with warnings and information about the SRS system in the car.

There is information in the following places.

Exterior decals

The decal on the driver's side of the windshield indicates that the vehicle is equipped with air bags in the steering wheel, dashboard, and seats.

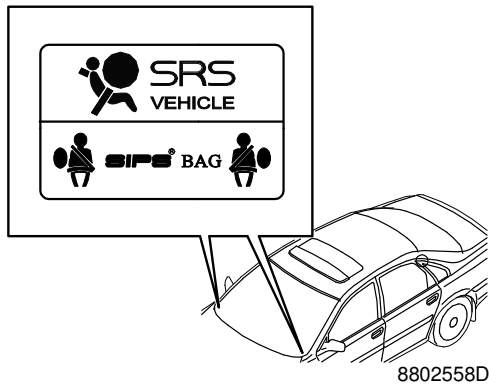

Interior decals

There are decals or embossed stamps on the steering wheel and dashboard indicating that the vehicle is equipped with driver and passenger airbags.

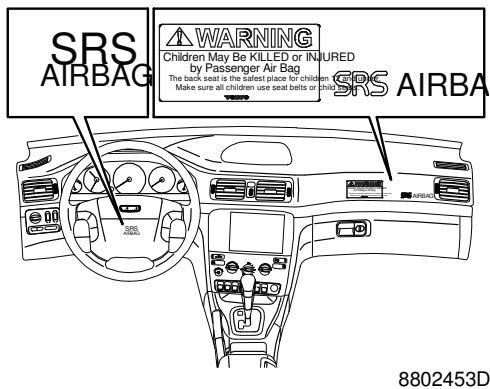

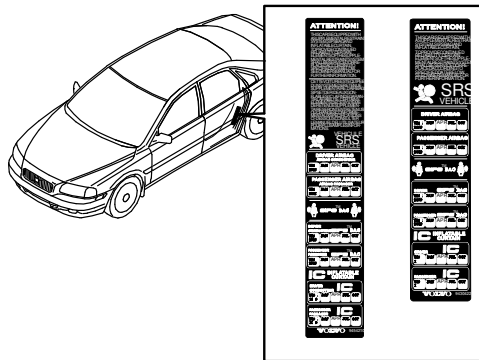

8802459D

There is a decal in the door opening for the rear side door showing all the airbag systems in the car.

In the C70 the decal is positioned on the lower section of the B-pillar.

In the S40 (-04)/V40 for USA/Canada, the decal is positioned on the lower section of the B-pillar.

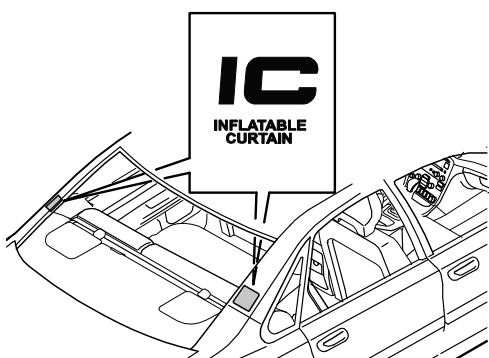

8802460D

S80

There is an embossed stamp on the C/D-pillars interior trim indicating that the vehicle is equipped with inflatable curtains.

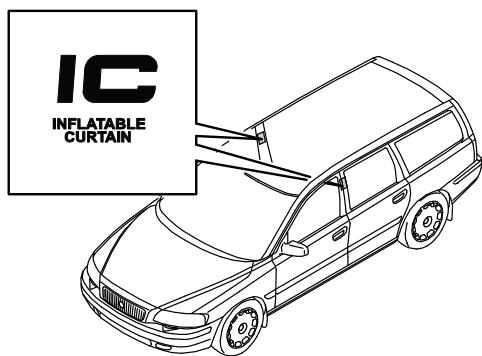

8802628M

V70 (01-)/V70 XC (01-)/XC70

There is an embossed stamp on the B-pillars interior trim indicating that the vehicle is equipped with inflatable curtains.

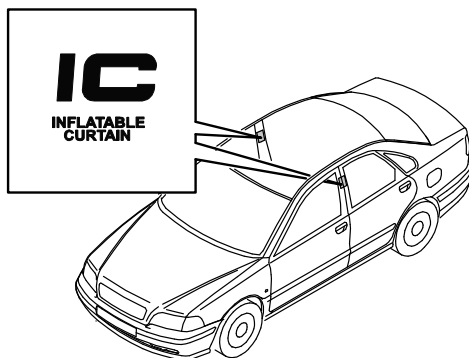

S40 (-04)

There is an embossed stamp on the B-pillars interior trim indicating that the vehicle is equipped with inflatable curtains.

8802627G

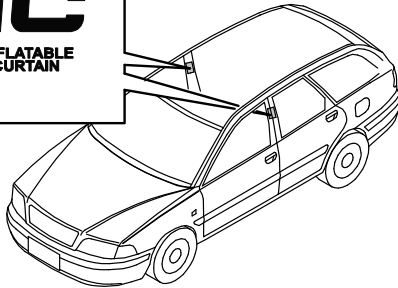

V40

There is an embossed stamp on the B-pillars interior trim indicating that the vehicle is equipped with inflatable curtains.

8802626G

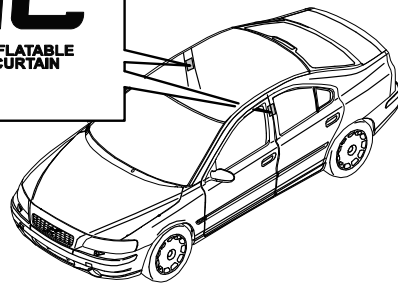

S60

There is an embossed stamp on the B-pillars interior trim indicating that the vehicle is equipped with inflatable curtains.

8802677M

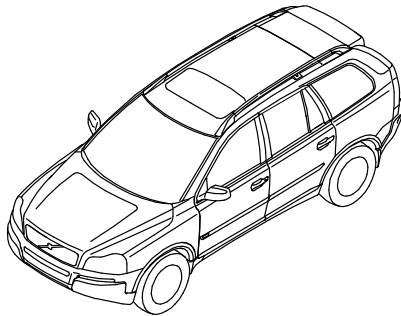

XC90

The XC90 does **not** have the embossing which indicates that the vehicle has inflatable curtains.

8802996R

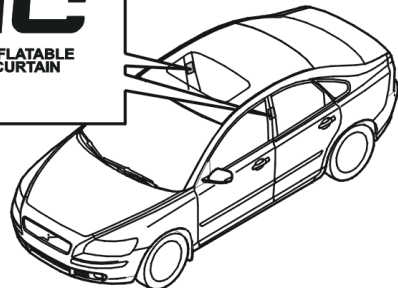

S40 (04.5-)

There is an embossed stamp on the B-pillars interior trim indicating that the vehicle is equipped with inflatable curtains.

8803384J

**V50**

There is an embossed stamp on the B- and C-pillars interior trim indicating that the vehicle is equipped with inflatable curtains.

8803385J

Interrupt the power supply

It is essential that the power supply is disconnected before the SRS system is subject to any shocks or vibration. If the ignition cannot be switched off, the battery must be disconnected.

The battery for S60/V70 (01-)/V70 XC (01-)/XC70/S80/XC90 are located in the cargo compartment (trunk). See illustrations below. The illustration shows the battery in the cargo compartment.

On all other models the battery is located under the hood.

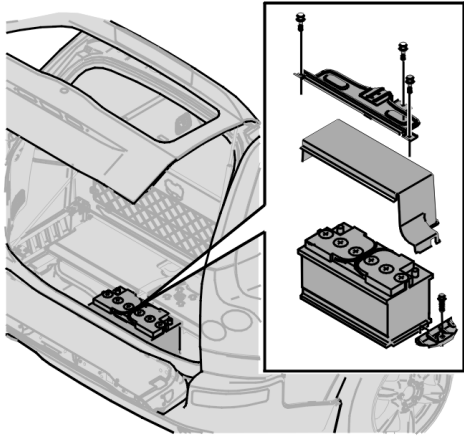

XC90

3100144r
3100144R

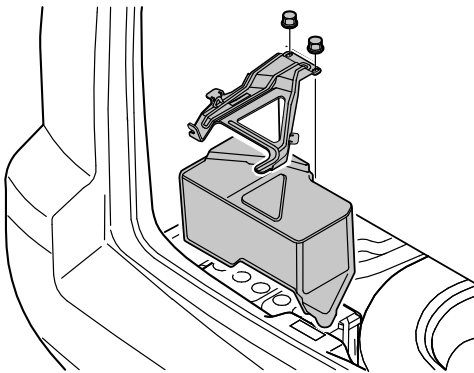

V70 (01-)/V70 XC (01-)/XC70

3602384M

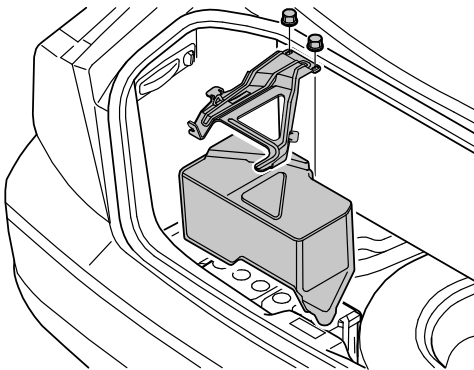

S80/S60

3601951M

Information about laminated side window glass

The glass in the side windows may be laminated.

NOTE! There is no marking to indicate that the glass is laminated.

This type of glass can only be broken with emergency tools and specialist saws which are equipped to saw through laminated windshields.

Saw through the side windows the same way as a windshield.

Make a hole and insert the saw. Saw into the window and lift it out.